

BATTISTA PORTERI S.R.L.

Via Statale 13

25060 Tavernole sul Mella (Brescia) ITALIA

Tel. 030/920131-920061-Fax 030/920783

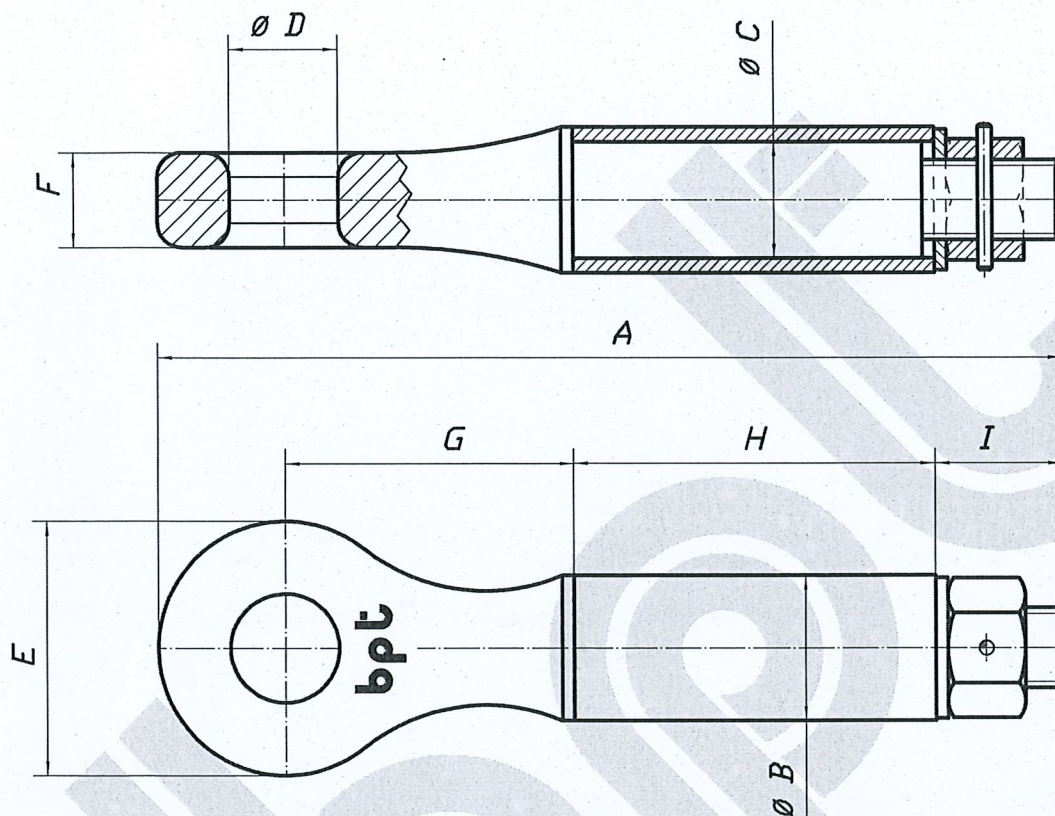

COD.	N° APPROVAZIONE	CARICO DINAMICO AMMESSO	A	ϕB	ϕC	ϕD	E	F	G	H	I
30043			275	42	30	32	80	28	87	118	30
30044	DGM RA-701E96	Kg. 900	343	48	38	45	95	35	120	135	40.5
30046	DGM RA-702F96	Kg. 1500	345	57	45	45	95	35	120	135	42.5
30047	DGM-RA 414E85	Kg. 2050	370	60	48	45	105	38	120	150	47.5

WIR FERTIGEN GESENKSCHMIEDETEILE
 DROP FORGING OUR BUSINESS
 NOUS ESTAMPONS TOUS LES ACIERS
 NOI STAMPIAMO L'ACCIAIO

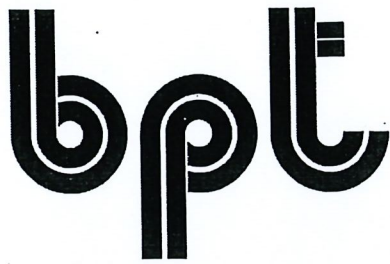

BATTISTA PORTERI S.R.L.

Via Statale 13

25060 Tavernole sul Mella (Brescia) ITALIA

Tel. 030/920131-920061-Fax 030/920783

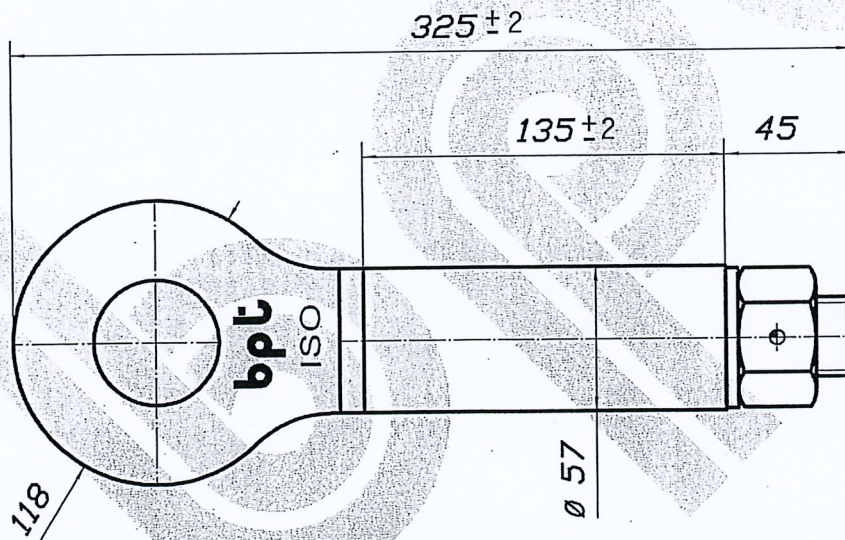
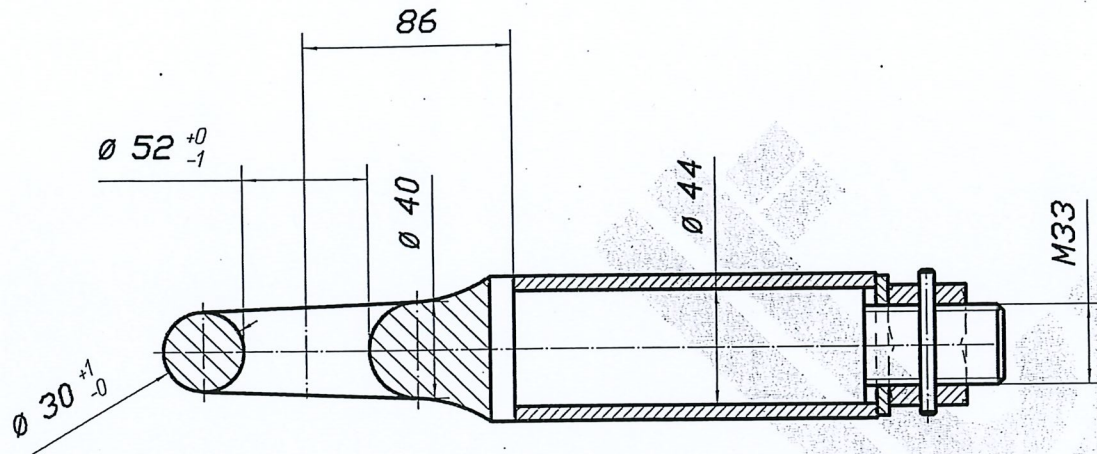

ANNEAU FRANCE NORMALE TOURNANT - ISO NORM 5692

COD.

30048

WIR FERTIGEN GESENKSCHMIEDETEILE
DROP FORGING OUR BUSINESS
NOUS ESTAMPONS TOUS LES ACIERS
NOI STAMPIAMO L'ACCIAIO

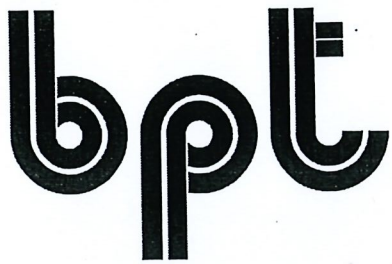

BATTISTA PORTERI S.R.L.

Via Statale 13

25060 Tavernole sul Mella (Brescia) ITALIA

Tel. 030/920131-920061-Fax 030/920783

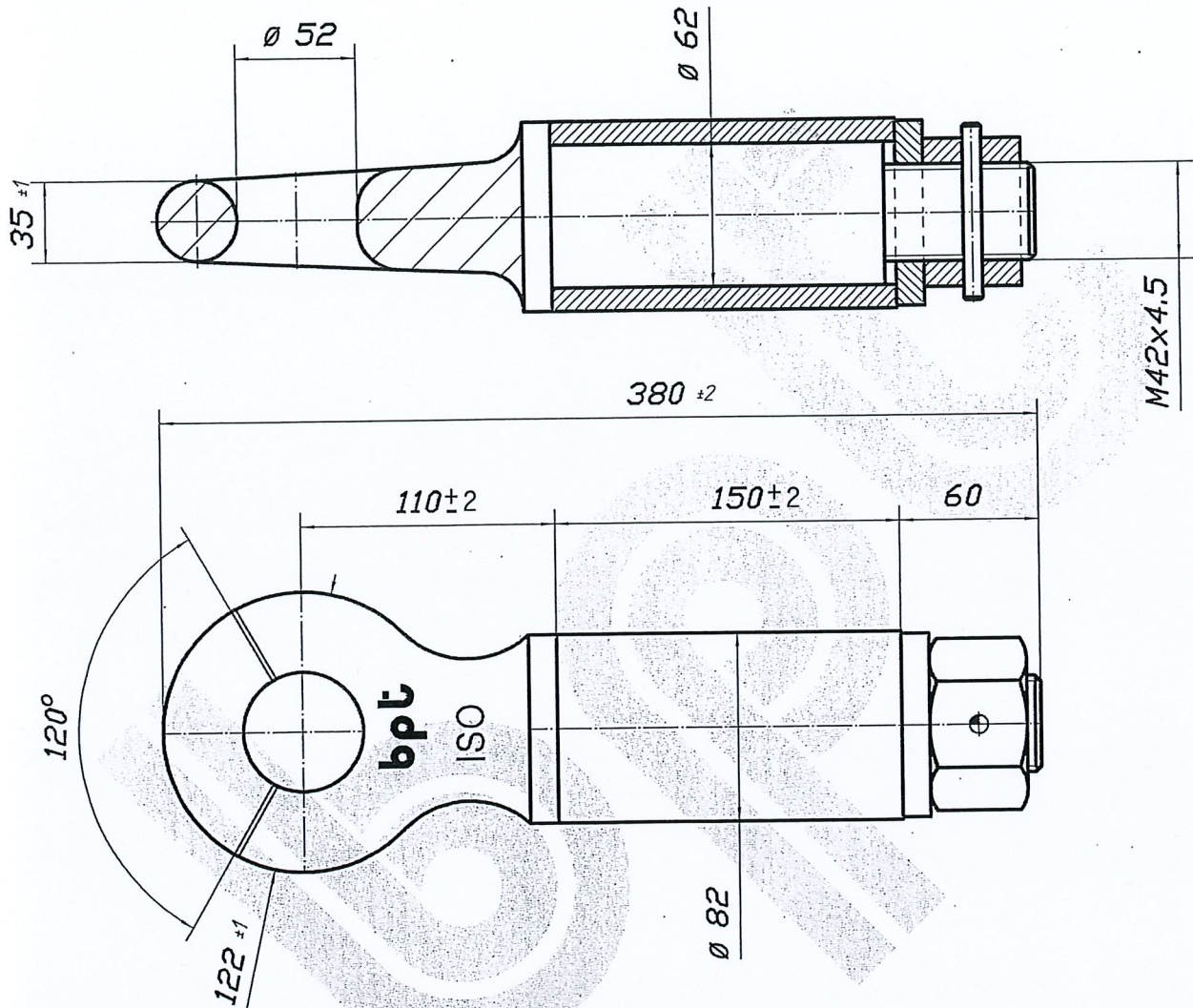

ANNEAU FRANCE - LOURD-ISO - HEAVY ISO NORM 5692

COD.

35001

WIR FERTIGEN GESENKSCHMIEDETEILE
DROP FORGING OUR BUSINESS
NOUS ESTAMPONS TOUS LES ACIERS
NOI STAMPIAMO L'ACCIAIO

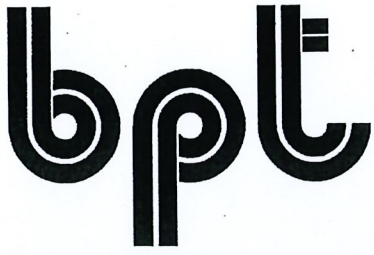

BATTISTA PORTERI S.R.L.

Via Statale 13

25060 Tavernole sul Mella (Brescia) ITALIA

Tel. 030/920131-920061-Fax 030/920783

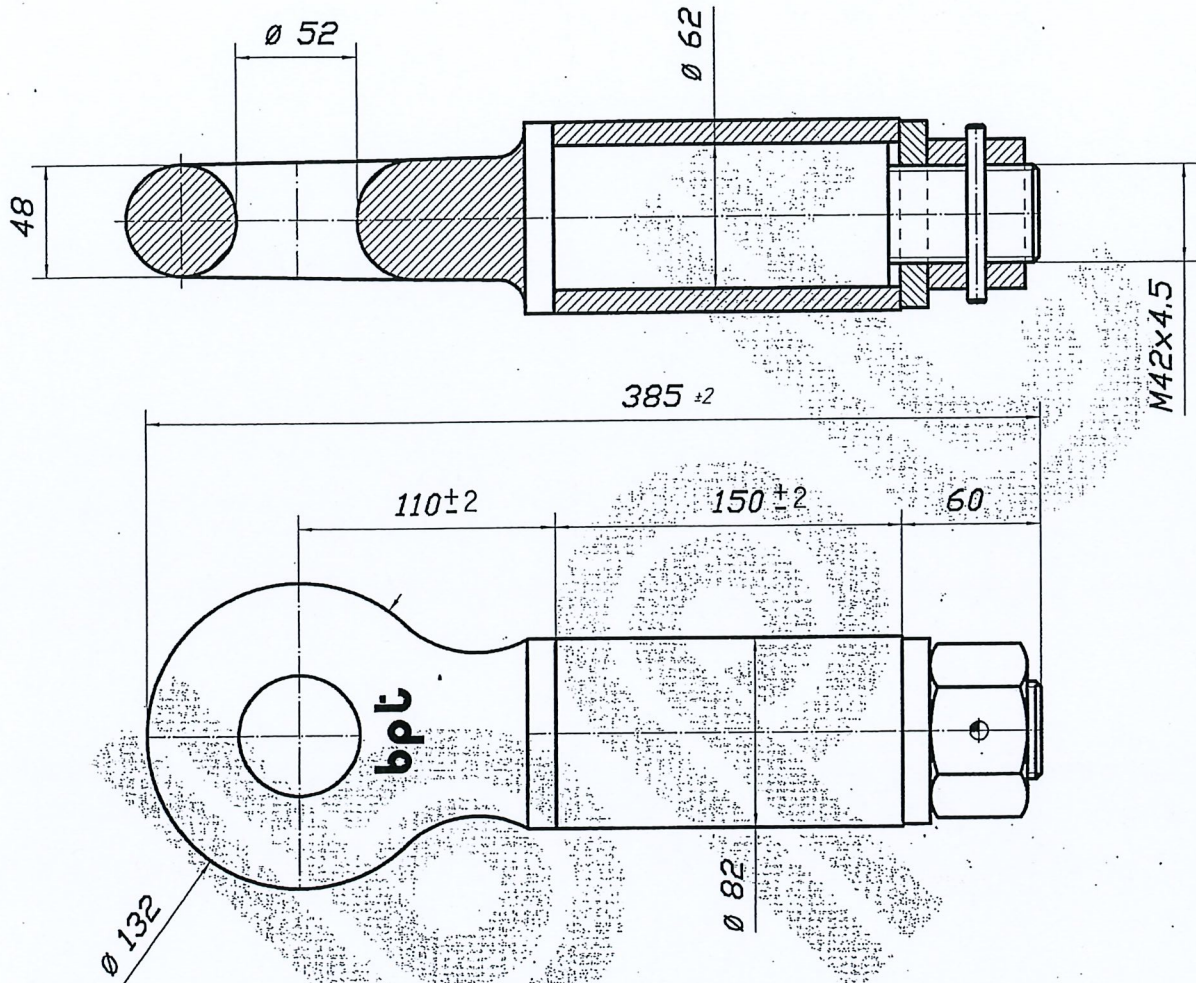

ANNEAU FRANCE LOURD TOURNANT
OCCHIONE FRANCIA PESANTE

COD.

30050

WIR FERTIGEN GESENKSCHMIEDETEILE
DROP FORGING OUR BUSINESS
NOUS ESTAMPONS TOUS LES ACIERS
NOI STAMPIAMO L'ACCIAIO

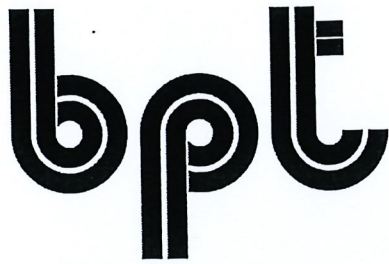

BATTISTA PORTERI S.R.L.

Via Statale 13

25060 Tavernole sul Mella (Brescia) ITALIA

Tel. 030/920131-920061-Fax 030/920783

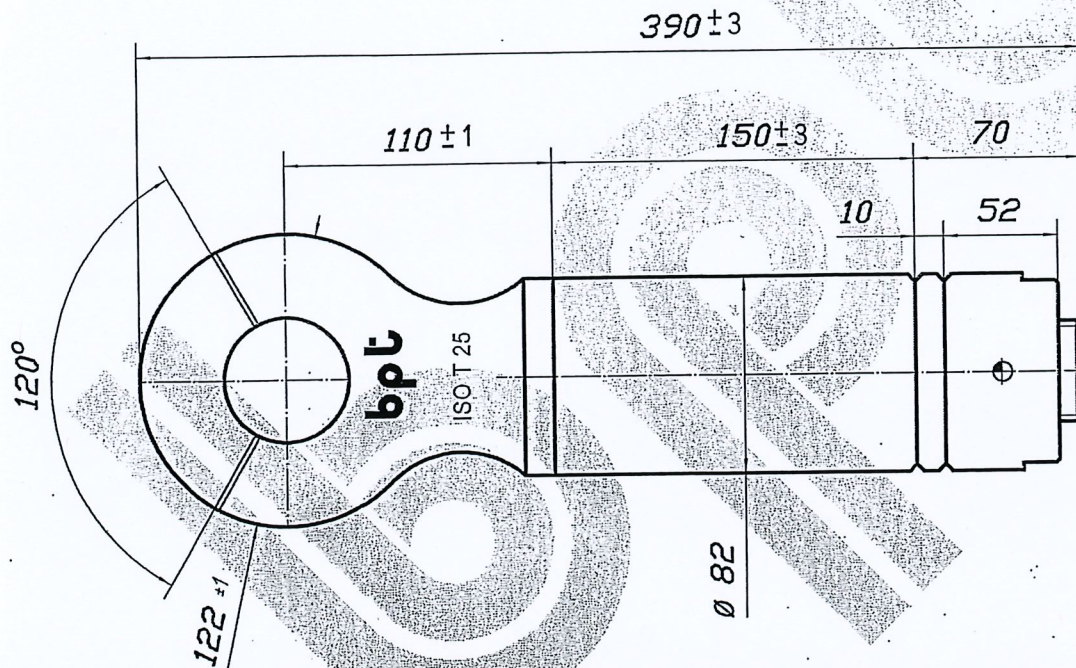
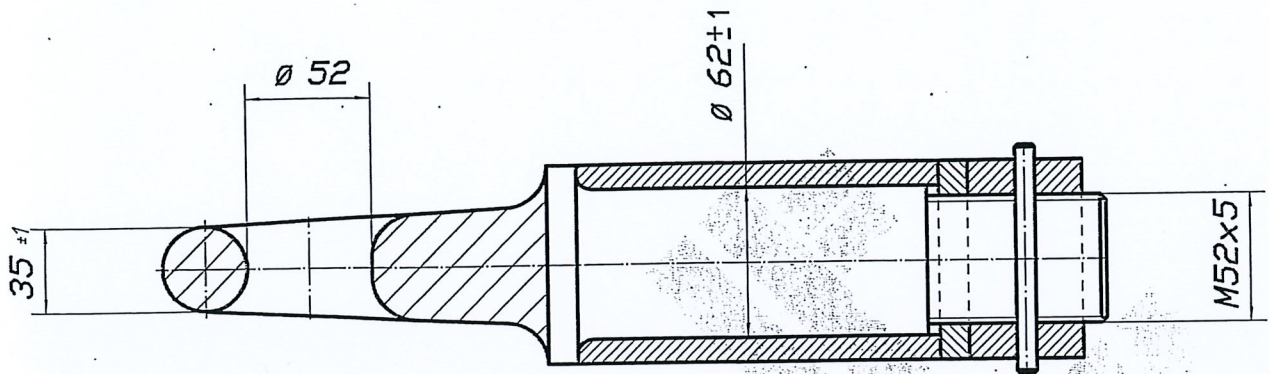

ANNEAU TYPE FRANCE LOURD TON 25 - ISO NORM
OCCHIONE TIPO FRANCIA PESANTE T25

COD.

35025

WIR FERTIGEN GESENKSCHMIEDETEILE
DROP FORGING OUR BUSINESS
NOUS ESTAMPONS TOUS LES ACIERS
NOI STAMPIAMO L'ACCIAIO

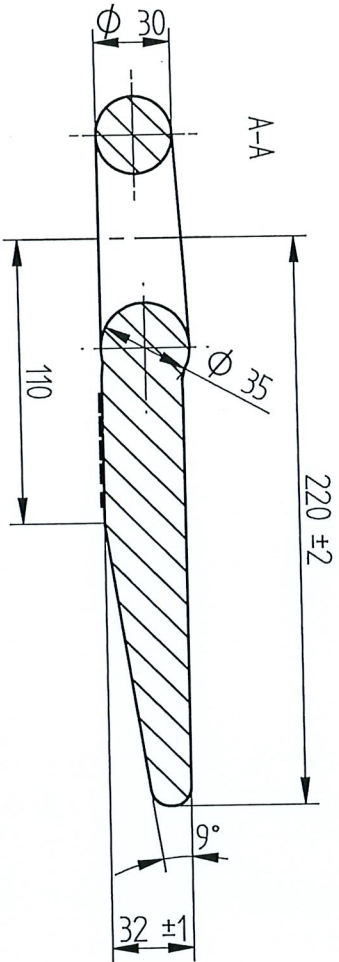
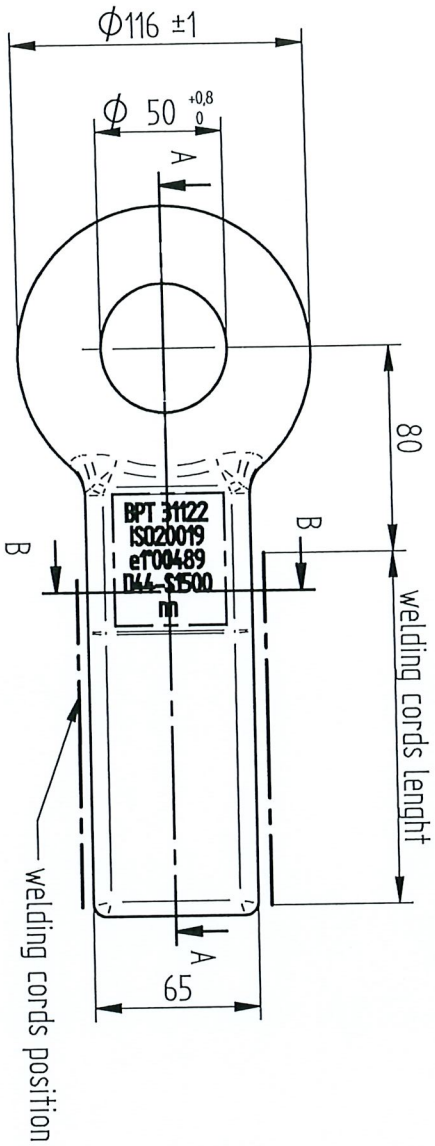

BPT 31122
ISO20019
e1*00489
D44-S1500
nm

MARKING

WELDING CORDS
SKETCH: dimension
a > 5 mm.

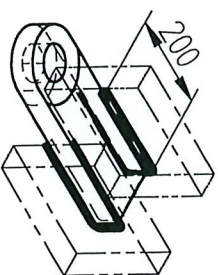

BPT hitch ring 31122 is according to ISO 20019 norm.

It shall used with follwing couplings:

-) ISO 6489/1 ; -) ISO 6489/4 ;

TOWING CAPABILITY. Example for D=44 kN: tractor 6t; trailer 18t

Rev. 00 - Date - 02/02/2018 - By: V.Ca	Rev. ___ Date _____ By _____	TOLLERANZE GENERALI SENZA INDICAZIONE General tolerances unless specified
Rev. ___ Date _____ By _____	Rev. ___ Date _____ By _____	UNI EN 22768-1 - GRADO / grade m

	DIMENSIONI IN mm Dimensions in mm	SCALA scale 1:2	MATERIALE Material	CODICE Part number	MASSA kg
			30MnCrB5	31122	3,847
DENOMINAZIONE - Name TAVERNOLE SUL MELLA (BS)		OCCHIONE		Nome file: 31122.dft MODIFICARE SOLO CON CAD. Handling on CAD system only	

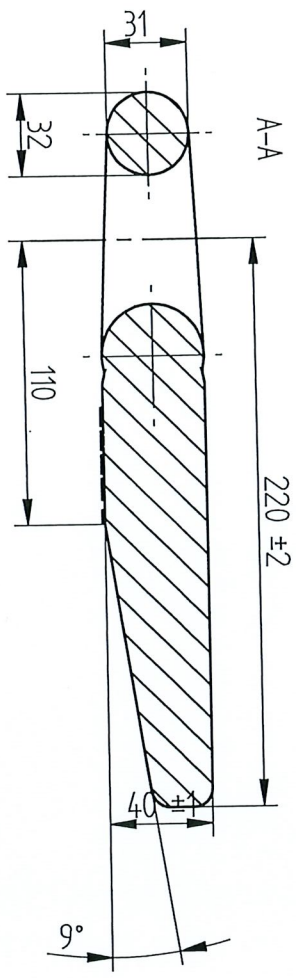
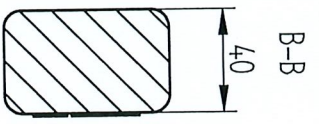
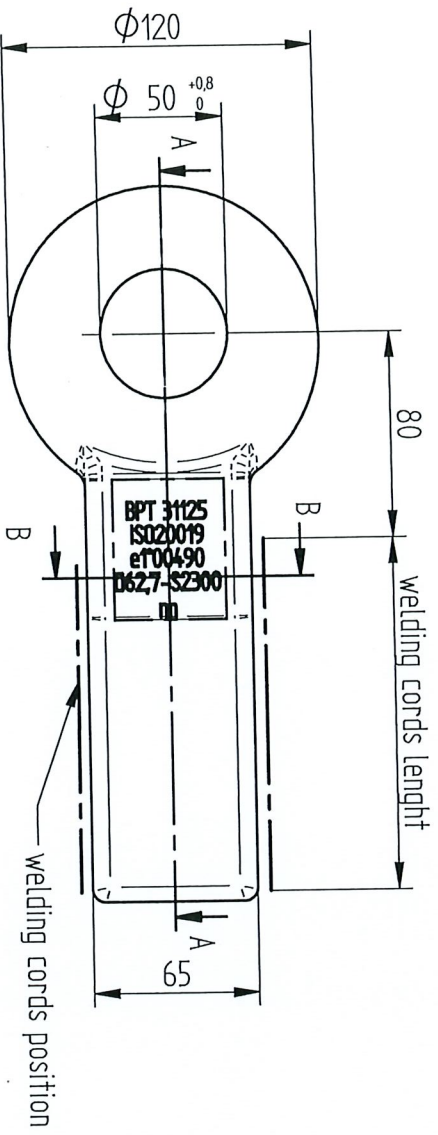

MARKING

BPT 31125
ISO20019
e1*00490
D62,7-S2300
mm

WELDING CORDS
SKETCH: dimension
a > 7 mm.

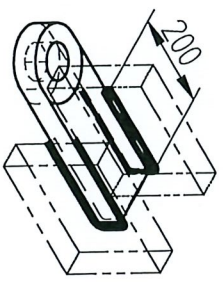

BPT hitch ring 31125 is according to ISO 20019 norm.
 It shall used with follwing couplings:
 -) ISO 6489/1 ; -) ISO 6489/4 ;
TOWING CAPABILITY. Example for D=62,7 kN: tractor 9t; trailer 22t

Rev. 00 - Date - 02/02/2018 - By: VCa	Rev. ___ Date _____ By _____	TOLLERANZE GENERALI SENZA INDICAZIONE General tolerances unless specified
Rev. ___ Date _____ By _____	Rev. ___ Date _____ By _____	UNI EN 22768-1 - GRADO / grade m

bppL		DIMENSIONI IN mm Dimensions in mm	
TAVERNOLE SUL MELLA (BS)		DENOMINAZIONE - Name	
OCCHIONE		SCALA scale 1:2	
CODICE Part number 31125		MATERIALE Material 30MnCrB5	
MASSA 4,927 kg		Nome file: 31125.dft	

MODIFICARE SOLO CON CAD, Handling on CAd system only

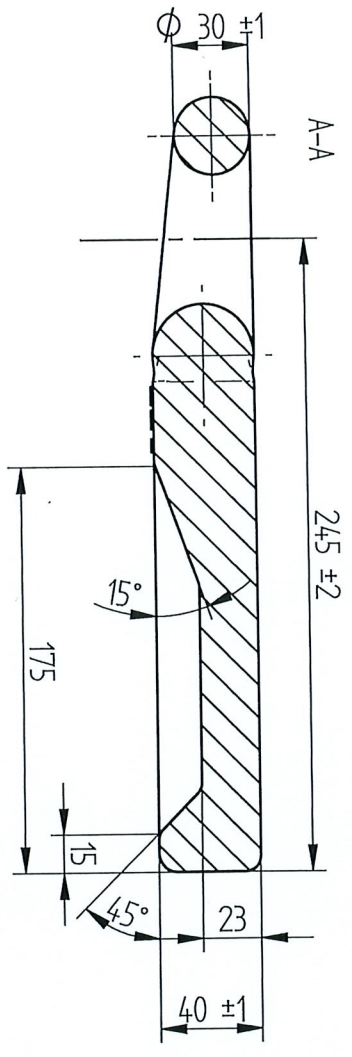
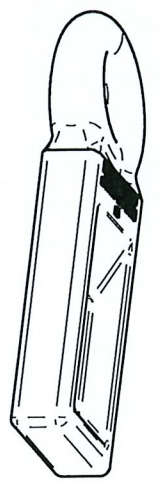
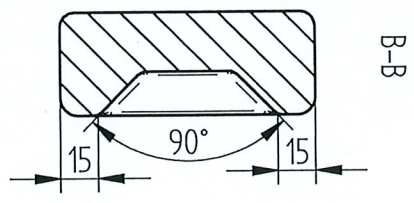
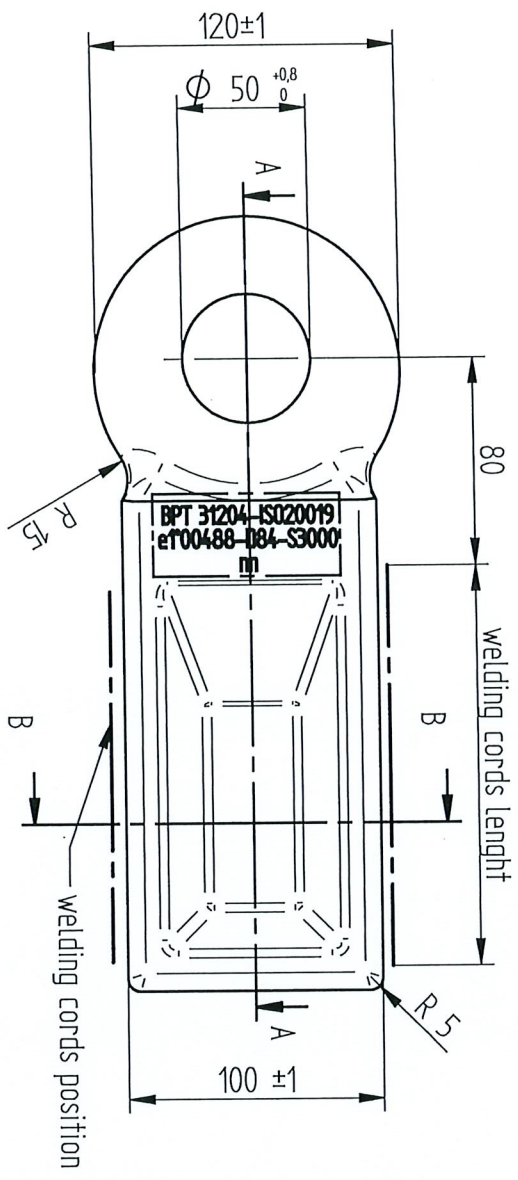

BPT 31204-ISO20019
e1*00488-D84-S3000
nn

WELDING CORDS
SKETCH: dimension
a > 7 mm.

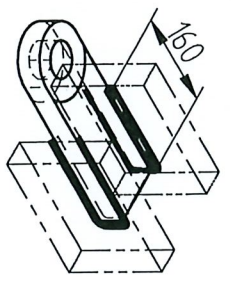

BPT hitch ring 31204 is according to ISO 20019 norm.

It shall used with follwing couplings:

-) ISO 6489/1 ; -) ISO 6489/4 ;

TOWING CAPABILITY. Example for D=84 kN: tractor 12t; trailer 30t

Rev. 00 - Date - 02/02/2018 - By: V.Ca	Rev. ___ Date ___ By ___	TOLLERANZE GENERALI SENZA INDICAZIONE General tolerances unless specified	UNI EN 22768-1 - GRADO / grade m
Rev. ___ Date ___ By ___	Rev. ___ Date ___ By ___		

	TAVERNOLE SUL MELLA (BS)	
	DIMENSIONI IN mm Dimensions in mm	DENOMINAZIONE - Name OCCHIONE UK
SCALA scale 1:2	MATERIALE Material 30MnCrB5	CODICE Part number 31204
MASSA 7,138 kg	Nome file: 31204.dff	

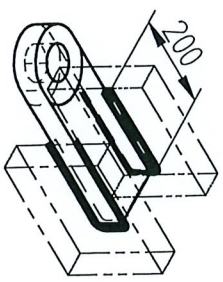
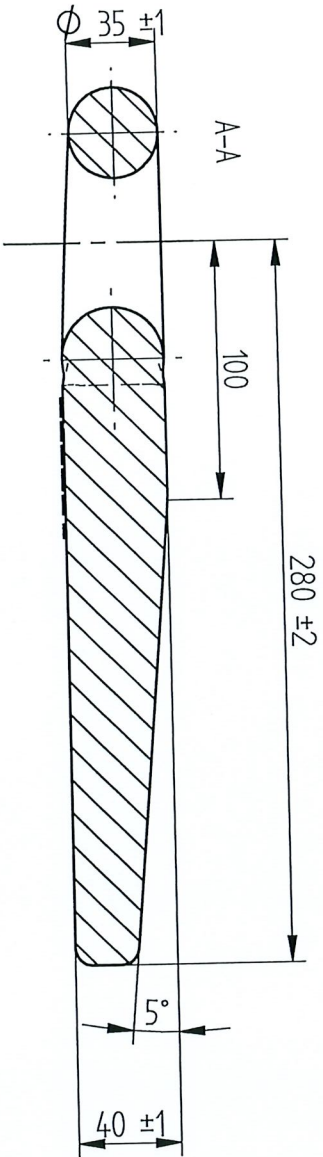
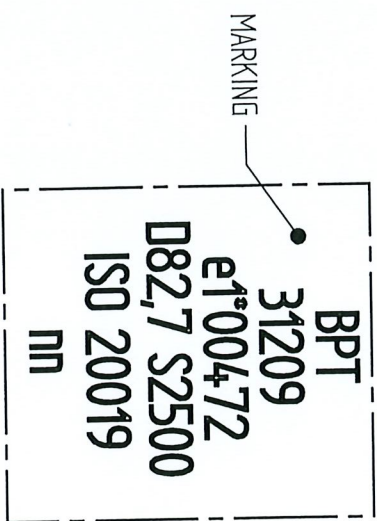
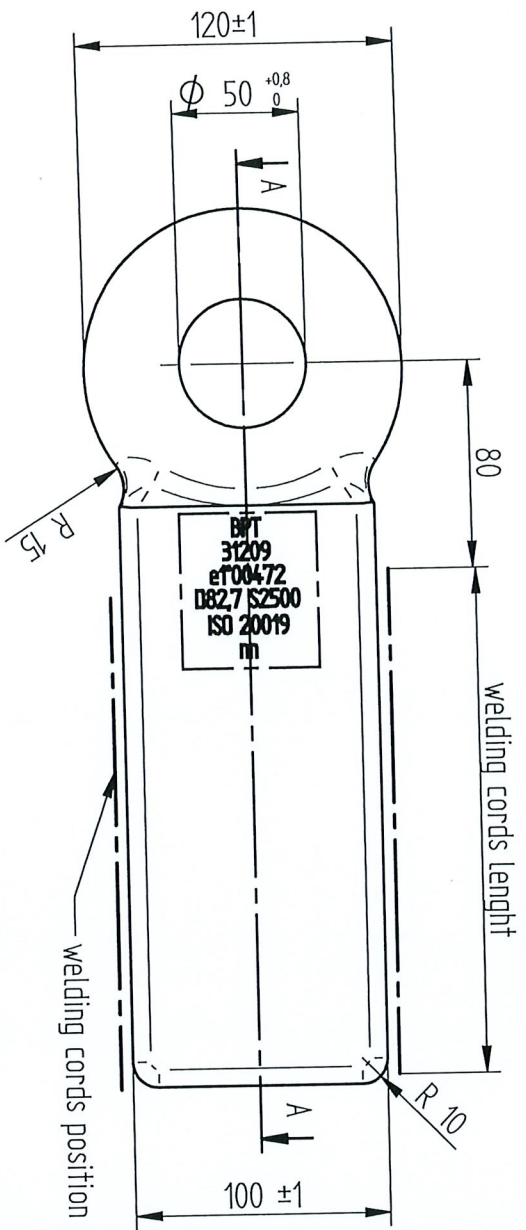

MODIFICARE SOLO CON CAD, inserendo on CAD system only



BPT hitch ring 31209 is according to ISO 20019 norm.
 It shall used with follwing couplings:

-) ISO 6489/1 ; -) ISO 6489/4 ;
TOWING CAPABILITY. Example for D=82,7 kN: tractor 12t; trailer 27t

Rev. 00 - Date - 02/02/2018 - By: V.Ca	Rev. _____ Date _____ By _____	TOLLERANZE GENERALI SENZA INDICAZIONE General tolerances unless specified
Rev. _____ Date _____ By _____	Rev. _____ Date _____ By _____	UNI EN 22768-1 - GRADO 7 grade m

		DIMENSIONI IN mm	
		 	
TAVERNOLE SUL MELLA (BS)		SCALA scale 1:2	
DENOMINAZIONE - Name		MATERIALE Material	
OCCHIONE BELGIO		S355J2G3	
CODICE Part number	31209	MASSA	8,244 kg
Name file: 31209.dft		MODIFICARE SOLO CON CAD, Interfacing on CAD system only	

WELDING CORDS
 SKETCH: dimension
 a > 7 mm.

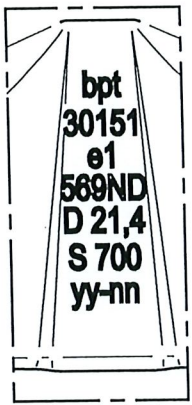
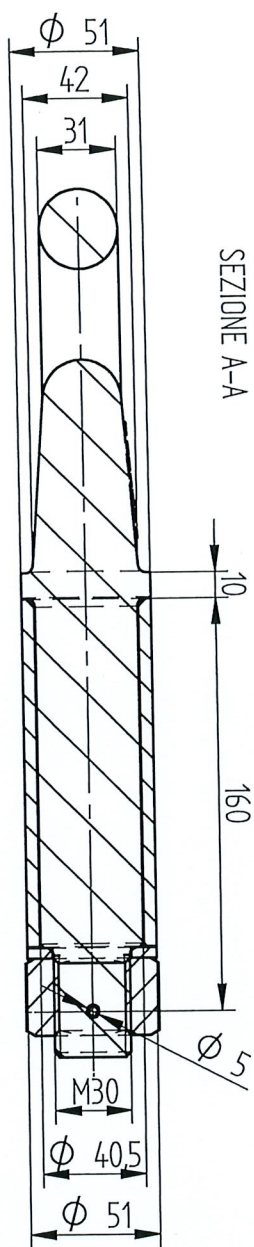

Marking

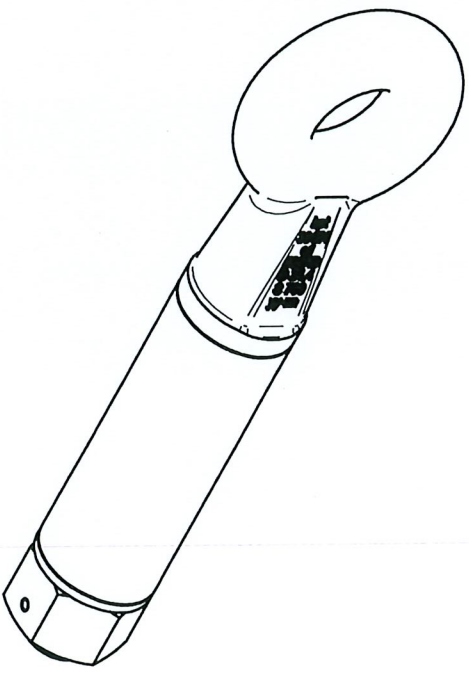
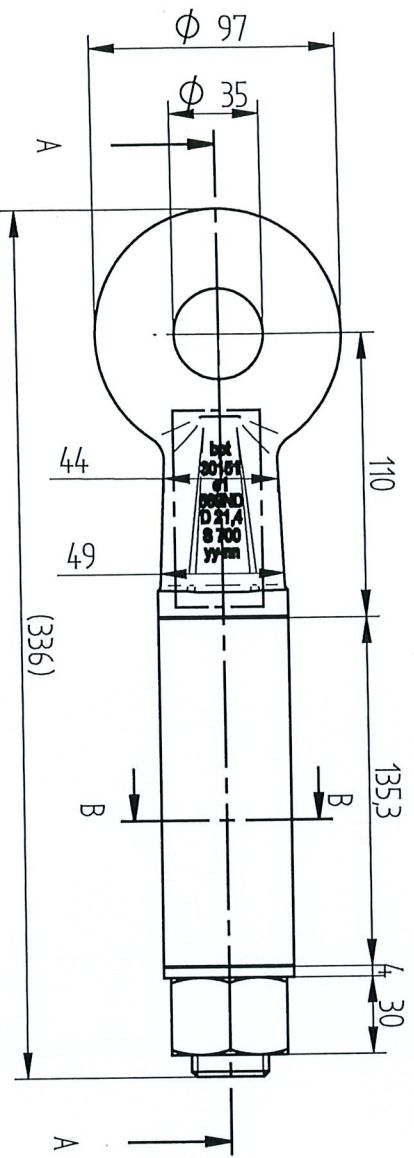

recommended welding cords:
min. 4 cords with $a > 5$ mm

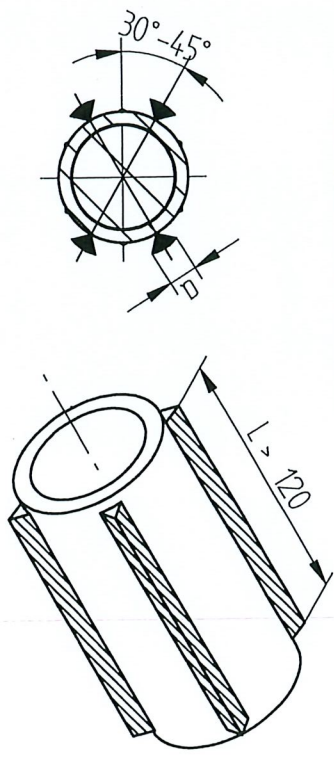

BPT ring eye 30151 is according to ISO 5692/3 (shape X) norm.
It shall used with follwing couplings: -) ISO 6489/5 (SHAPE X)
TOWING CAPABILITY. Example for D=21,4 kN: tractor 3t; trailer 8t

Rev. 00 - Date - 06/02/2018 - By: V.Ca	Rev. _____ Date _____ By _____	TOLLERANZE GENERALI SENZA INDICAZIONE General tolerances unless specified
Rev. _____ Date _____ By _____	Rev. _____ Date _____ By _____	UNI EN 22768-1 - GRADO / grade m

bpt		DIMENSIONI IN mm Dimensions in mm	
TAVERNOLE SUL MELLA (BS)		SCALA scale	
DENOMINAZIONE - Name OCCH. E3 - ASSY		MATERIALE Material	
CODICE Part number 30151		MASSA 4,724 kg	
Name file: 30151-ASSY.dft			

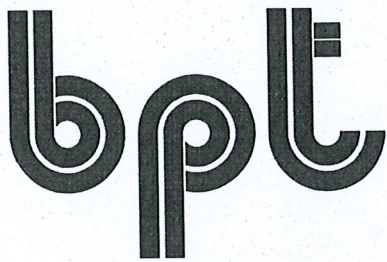

BATTISTA PORTERI S.R.L.

Via Statale 13

25060 Tavernole sul Mella (Brescia) ITALIA

Tel. 030/920131-920061-Fax 030/920783

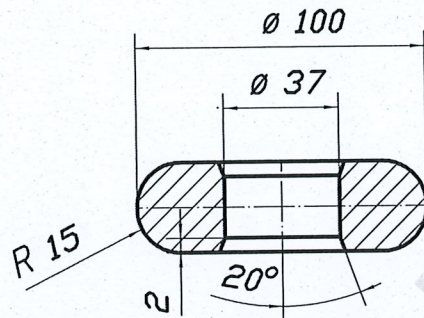

WIR FERTIGEN GESENKSCHMIEDETEILE
DROP FORGING OUR BUSINESS
NOUS ESTAMPONS TOUS LES ACIERS
NOI STAMPIAMO L'ACCIAIO

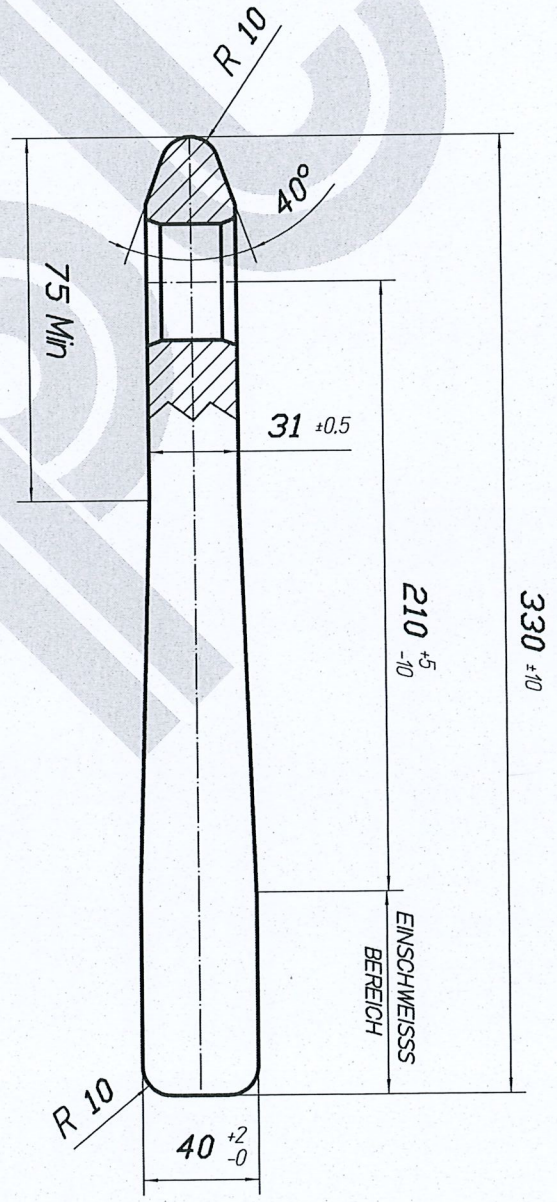
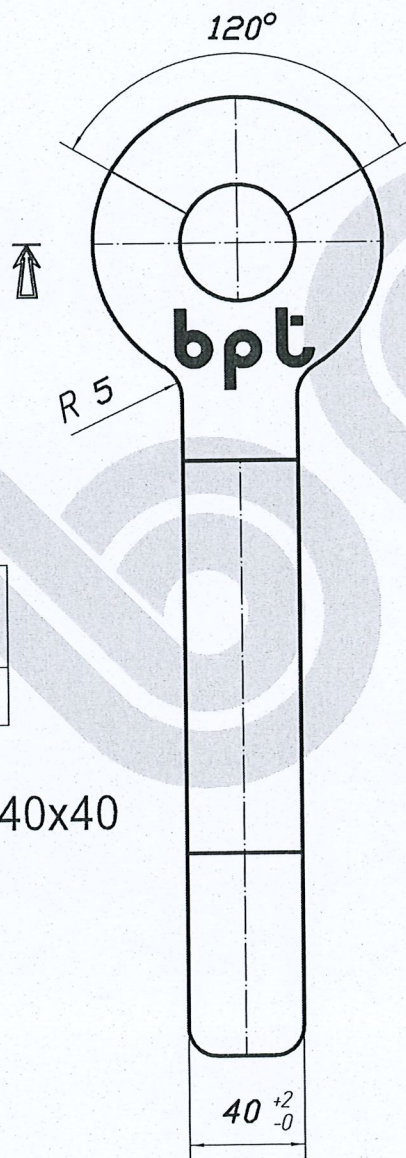

COD.
30140

OCCHIONE 40x40

BPT ring eye 30150 is according to ISO 8755 and DIN 74054 norms. TOWING CAPABILITY. Example for D=27kN: tractor 3,75t, trailer 10,4t
 It shall used with following couplings:
 -) ISO 6489-2;
 -) ISO 6489-3 cat. 1 and cat. 2

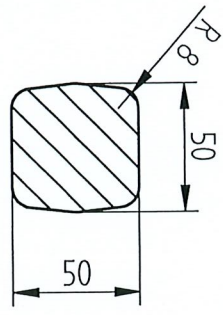
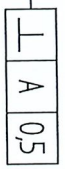
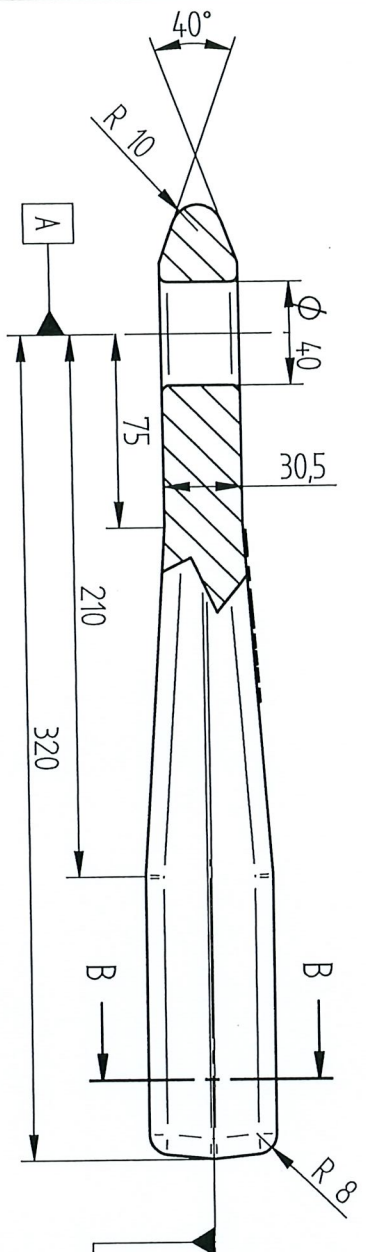

B-B

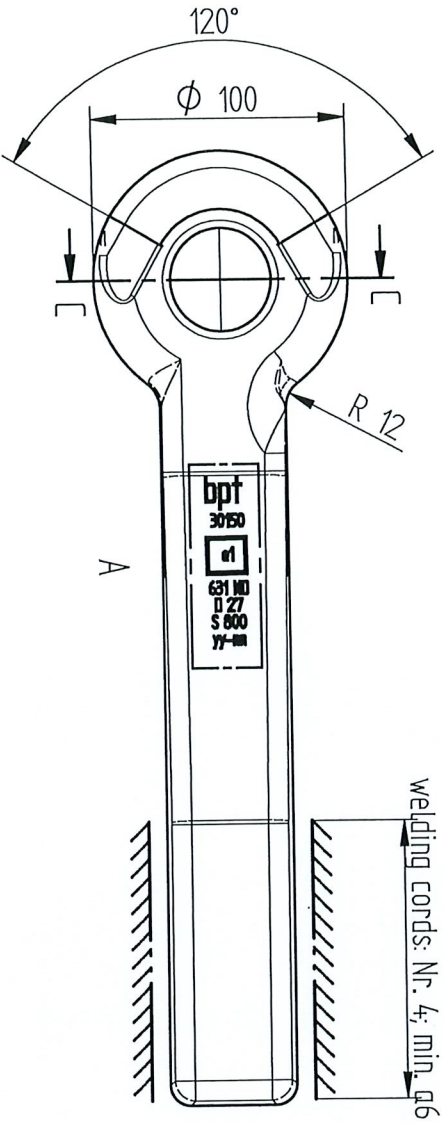
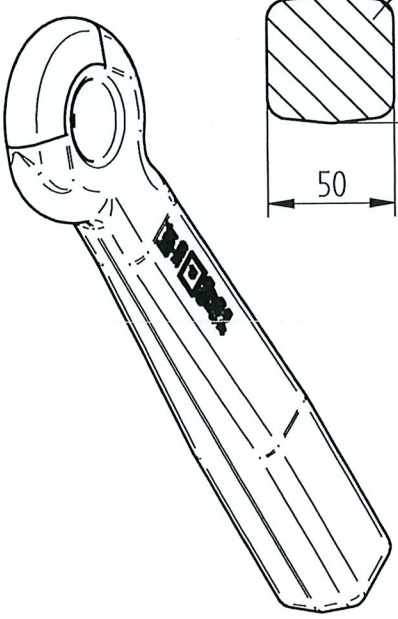

welding cords: Nr. 4; min. q6

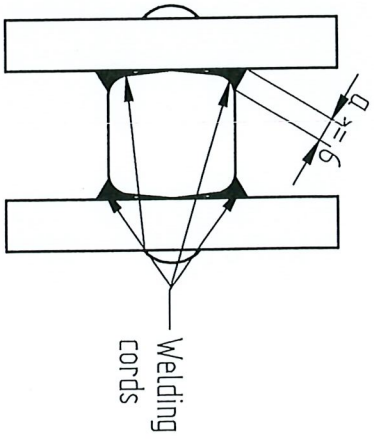
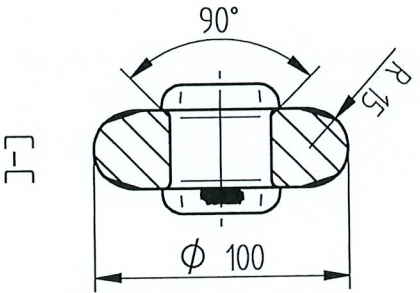

bpt
30150
e1
631 ND
D 27
S 800
yy-nn

DETT. A

Rev. 00 - Date - 01/09/2019 - By: V.Ca	Rev. _____ Date _____ By _____	TOLLERANZE GENERALI SENZA INDICAZIONE General tolerances unless specified
Rev. _____ Date _____ By _____	Rev. _____ Date _____ By _____	UNI EN 22768-1 - GRADO / grade m

bpt		DIMENSIONI IN mm Dimensions in mm	
TAVERNOLE SUL MELLA (BS)		SCALA scale	
Dichione a saldare		MATERIALE Material	
DENOMINAZIONE - Name		EN S355J2	
CODICE Part number		MASSA kg	
30150		5,516	
Nome file: 30150.dft		MODIFICARE SOLO CON CAD, Handling or CAD system only	

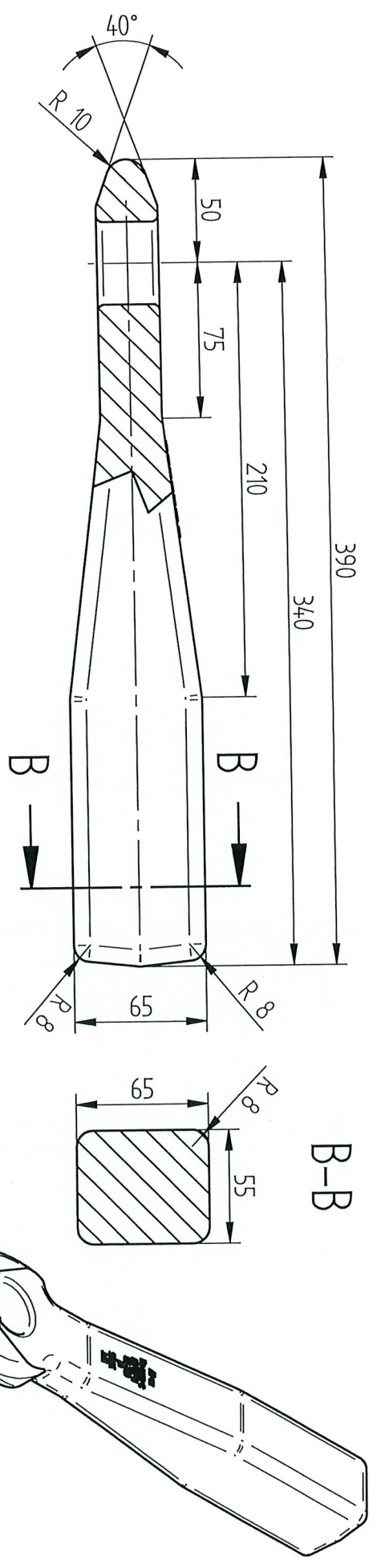

BPT 30155
e1
632 ND
D=38 kN
S=1200 kg
nn-yy

welding cords: Nr. 4; min. q.7

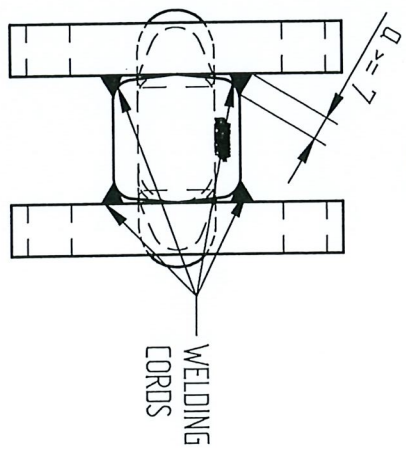
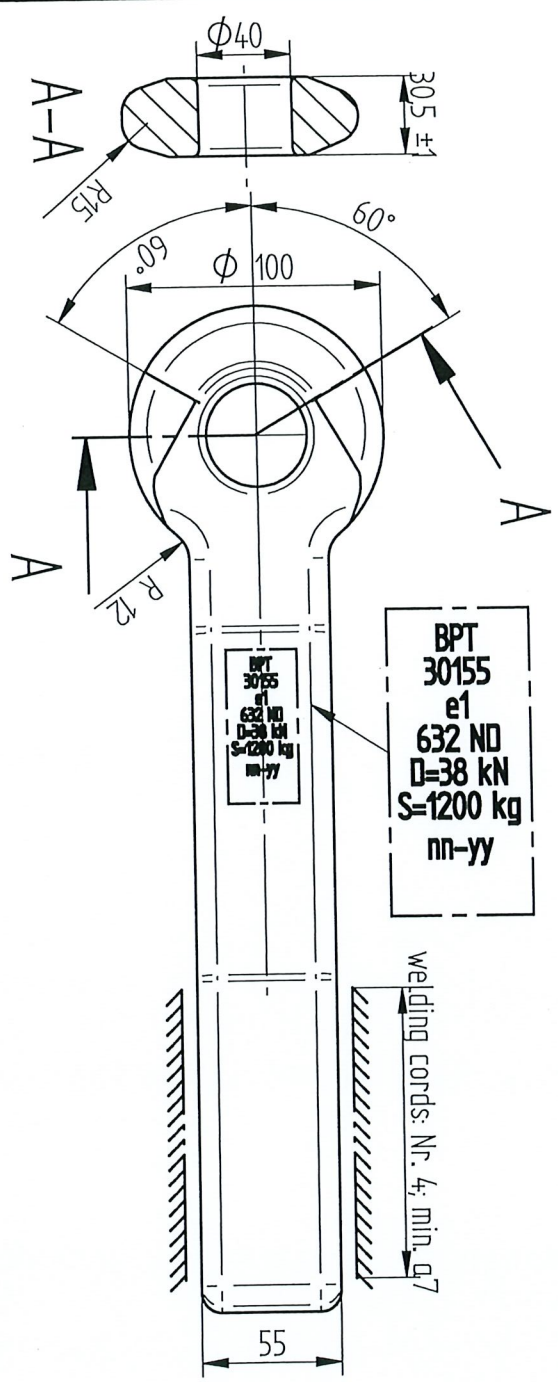

BPT ring eye 30155 is according to ISO 8755 and DIN 74054 norms. TOWING CAPABILITY. Example for D=38kN: tractor 5,25t, trailer 14,75t
 It shall used with follwing couplings:

-) ISO 6489-2;
-) ISO 6489-3 cat. 1 and cat. 2

Rev. 00 - Date - 21/08/2019 - By: V.Ca	Rev. _____ Date _____ By _____	TOLLERANZE GENERALI SENZA INDICAZIONE General tolerances unless specified
Rev. _____ Date _____ By _____	Rev. _____ Date _____ By _____	UNI EN 22768-1 - GRADO / grade m

		DIMENSIONI IN mm	SCALA	MATERIALE	CODICE Part number 30155	MASSA 7,921 Kg
		Dimensions in mm	scale	Material		
TAVERNOLE SUL MELLA (BS)		DENOMINAZIONE - Name	Occhione ISO 8755		EN S355L253	

Nome file: 30155.dft
 MODIFICARE SOLO CON CAD, Handling on CAD system only

SEZIONE A-A

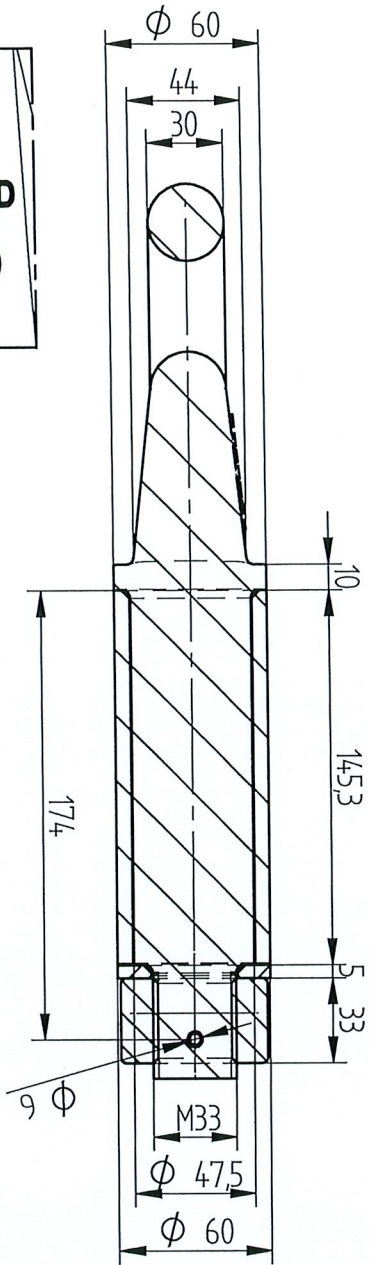

**bpt
30161
e1
00590ND
D 33,4
S 1250
yy-yy**

MARCHING

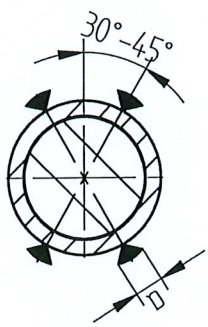
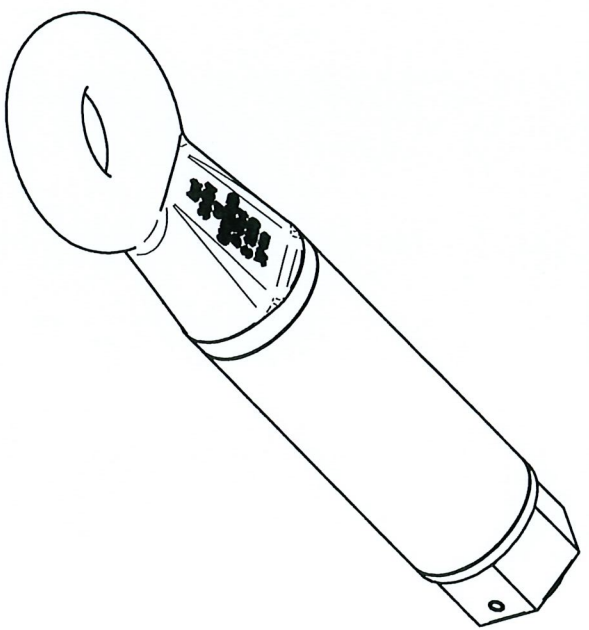
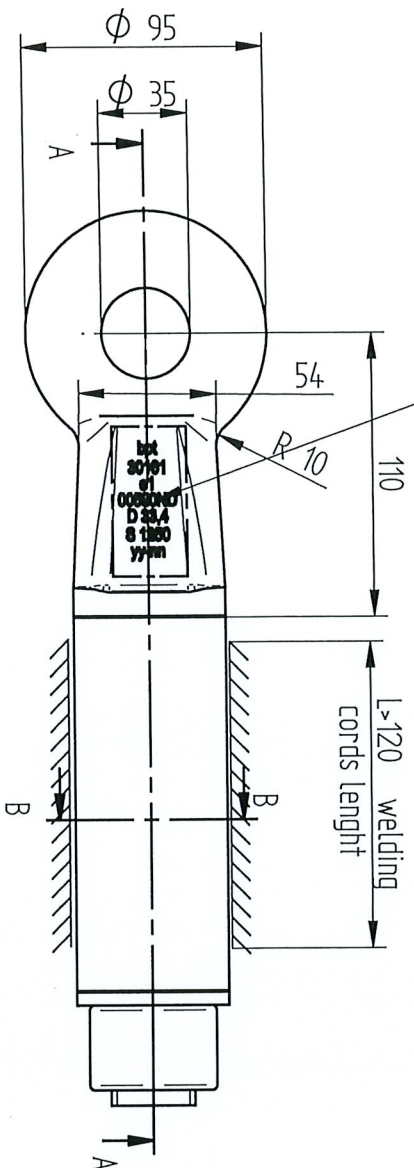

recommended welding
cords: min. nr. 4 cords
with a > 6 mm

BPT ring eye 30161 is according to ISO 5692/3 (shape X) norm.

It shall used with following couplings:

-) ISO 6489/5 (SHAPE X)

TOWING CAPABILITY. Example for D=33,4 KN: tractor 4.5t; trailer 14t

Rev. 00 - Date - 20/12/2018 - By: V.Ca	Rev. ___ Date _____ By _____	TOLLERANZE GENERALI SENZA INDICAZIONE General tolerances unless specified
Rev. ___ Date _____ By _____	Rev. ___ Date _____ By _____	UNI EN 22768-1 - GRADO / grade m

bpt		DIMENSIONI IN mm Dimensions in mm	
TAVERNOLE SUL MELLA (BS)		SCALA scale	
DENUMINAZIONE - Name HITCH RING		MATERIALE Material	
CODICE Part number 30161		MASSA 6,146 kg	

Pos	P.N.	Description	Material	Qty
1	30201-L	Corpo Occhione Lav.	30MnCr85+QT	1
2	35202	bussola pesante	EN S355 J0	1
3	35206	rondella pesante	EN C40	1
4	35204	Dado M4,2x4,5	Class 8.8	1
5	35208	Spina el. ISO 13337 - 8x65	Acciaio St	1

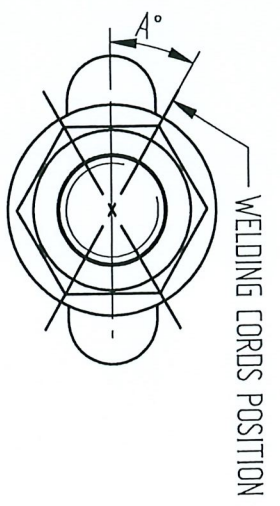
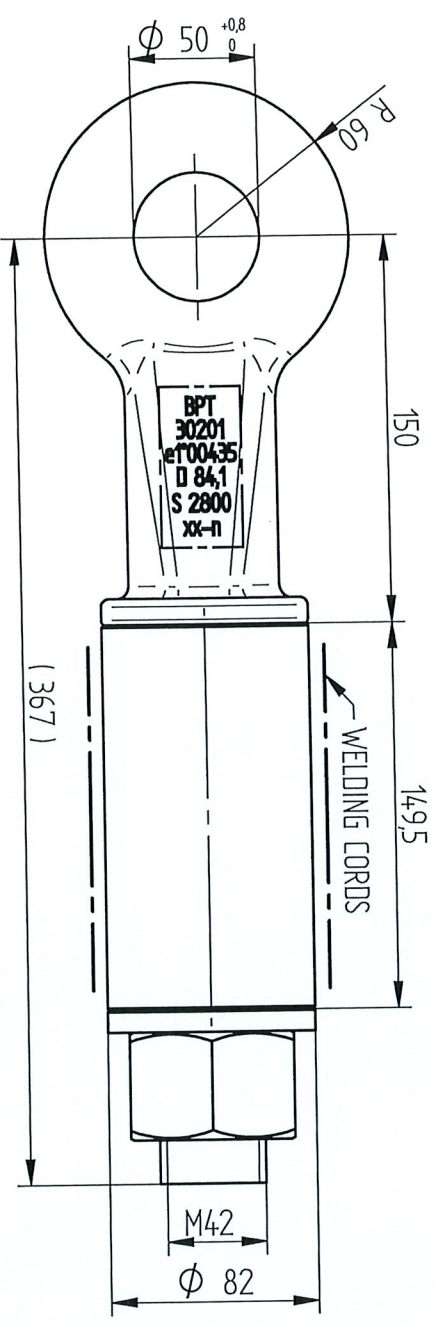
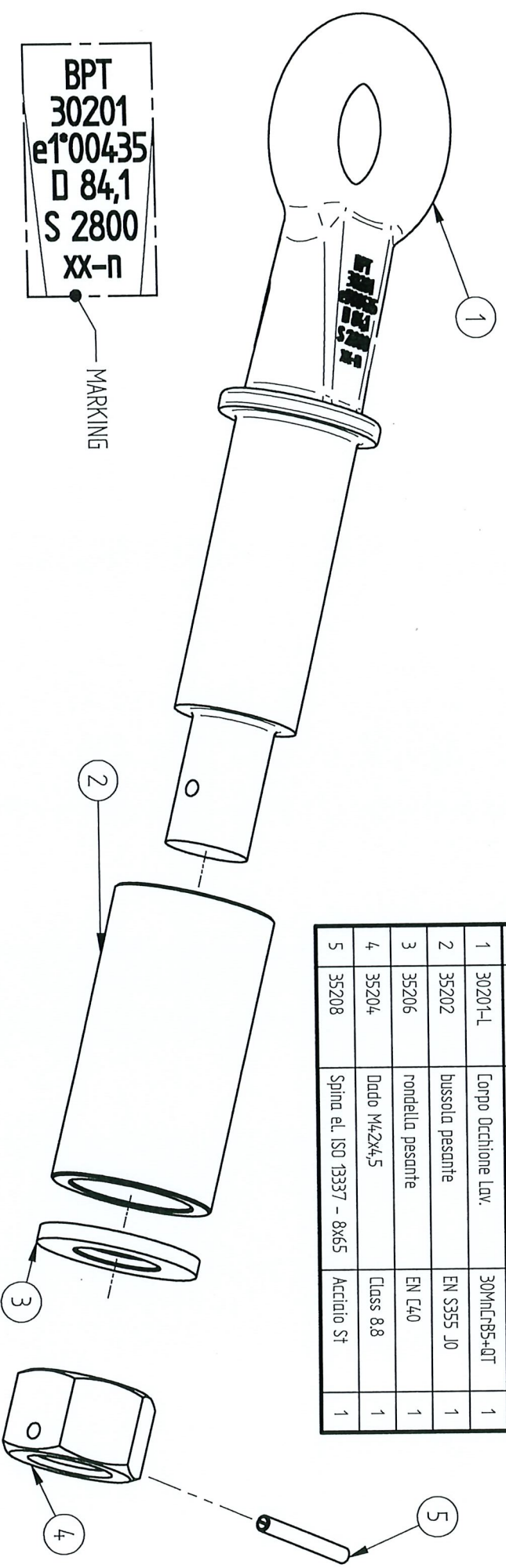

fix bushing trough nr 4 welding cords with $30^\circ < A^\circ < 45^\circ$, $a > 7\text{mm}$ and length $> 140\text{mm}$

BPT ring eye 30201 is according to ISO 5692/3 (shape Y) norm.

It shall used with follwing couplings:

-) ISO 6489/1 ; -) ISO 6489/4 ; -) ISO 6489/5 (SHAPE Y)

TOWING CAPABILITY. Example for D=45,8 kN: tractor 12t; trailer 30t

Rev. 00 - Date - 20/11/2017 - By V. Cast	Rev. ___ Date _____ By _____	TOLLERANZE GENERALI SENZA INDICAZIONE General tolerances unless specified UNI EN 22768-1 - GRADO / grade m
Rev. ___ Date _____ By _____	Rev. ___ Date _____ By _____	

bpu
TAVERNOLE SUL MELLA (BS)

DENOMINAZIONE - Name: Occhione EU pesante

CODICE Part number: 30201

MASSA: 12,021 kg

**BPT
30211
e1
00529ND
D 36,5
S 1000
nn**

MARKING

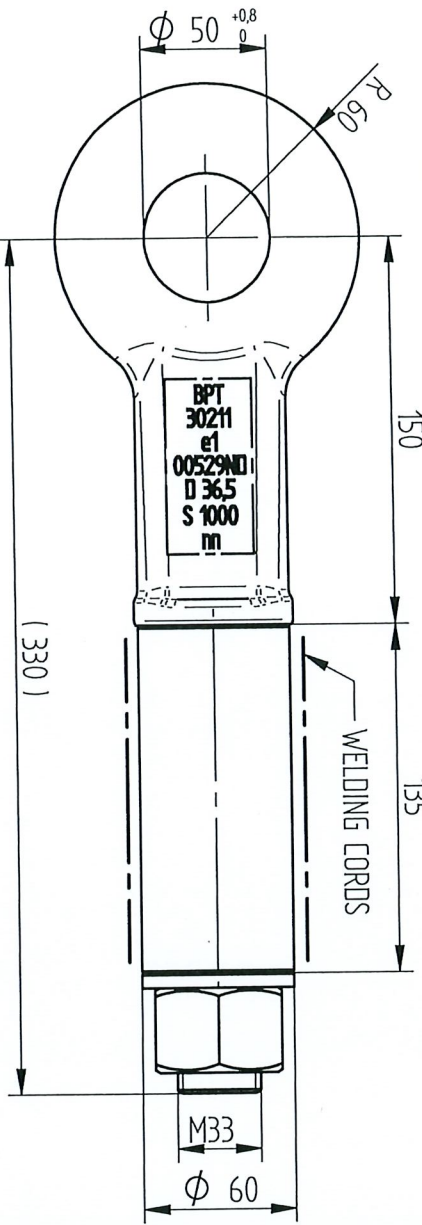
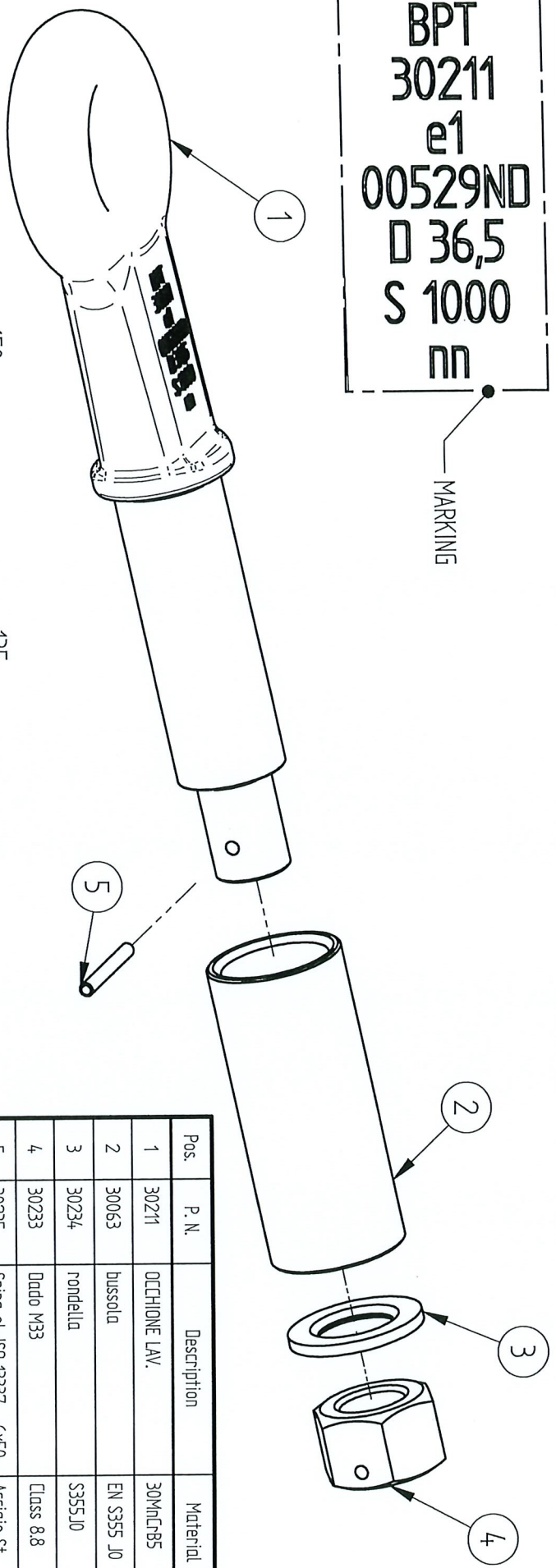

Pos.	P. N.	Description	Material	Qty
1	30211	OCCHIONE LAV.	30MnCr-B5	1
2	30063	bussola	EN S355 J0	1
3	30234	pondella	S355 J0	1
4	30233	Dado M33	Class 8.8	1
5	30235	Spina el. ISO 13337 - 6x50	Acciaio St	1



weldings position

fix bushing trough nr 4 welding cords with
30° < A° < 45°, a > 5mm and lenght > 125mm

BPT ring eye 30211 is according to ISO 5692/3 (shape Y) norm.

It shall used with follwing couplings:

-) ISO 6489/1 ; -) ISO 6489/4 ; -) ISO 6489/5 (SHAPE Y)

TOWING CAPABILITY. Example for D=36,5 KN: tractor 5t; trailer 14,5t

Rev. 00 - Date - 02/11/2017 - By: V.Ca	Rev. _____ Date _____ By _____	TOLLERANZE GENERALI SENZA INDICAZIONE General tolerances unless specified
Rev. _____ Date _____ By _____	Rev. _____ Date _____ By _____	UNI EN 22768-1 - GRADO / grade m

**TAVERNOLE SUL
MELLA (BS)**

DIMENSIONI IN mm Dimensions in mm	 	SCALA scale	MATERIALE Material	CODICE Part number	MASSA kg
DENOMINAZIONE - Name				30211	6,499
OCCHIONE				Nome file: 30211dft	

MODIFICHE SOLO CON CAD. Handling on CAD system only.

BPT
30248
e1°00436
D 45,8
S 1600
mm

MARKING

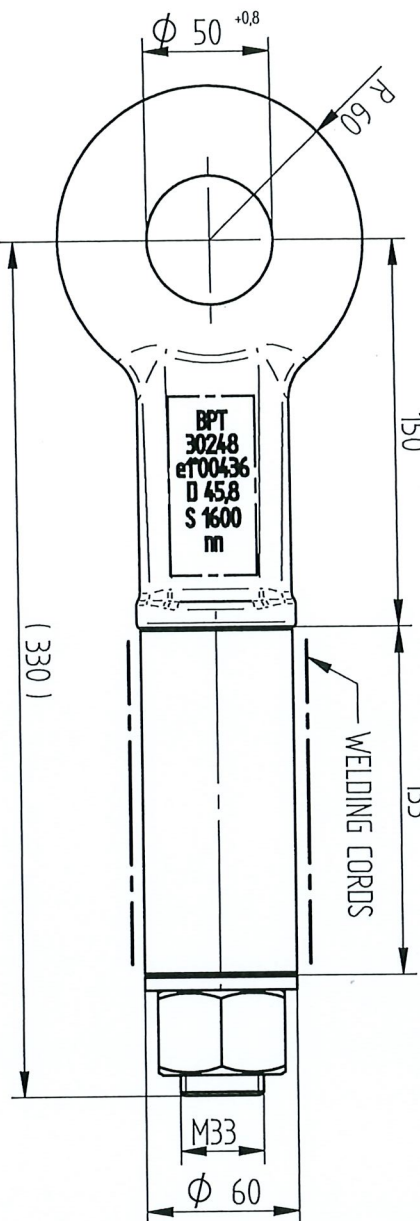
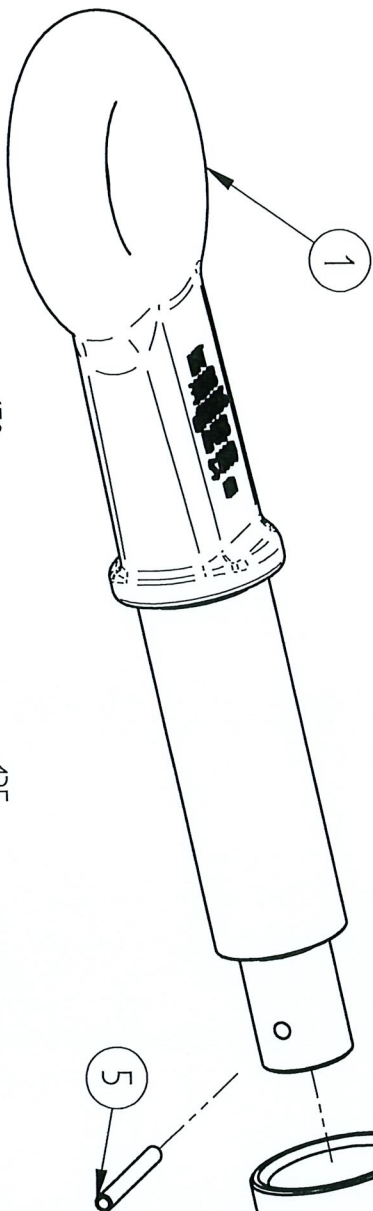

Pos.	P. N.	Description	Material	Qty
1	30248	OCCHIONE LAV.	30MnCrBS-qT	1
2	30063	bussola	EN S355 J0	1
3	30234	rondella	S355 J0	1
4	30233	Dado M33	Class 8.8	1
5	30235	Spina el. ISO 13337 - 6x50	Acciaio St	1

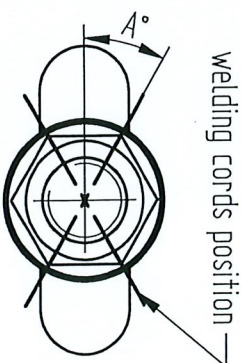

welding cords position

fix bushing trough nr 4 welding cords with
30° < A < 45°, a > 5mm and lenght > 125mm

BPT ring eye 30248 is according to ISO 5692/3 (shape Y) norm.

It shall used with following couplings:

-) ISO 6489/1 ; -) ISO 6489/4 ; -) ISO 6489/5 (SHAPE Y)

TOWING CAPABILITY. Example for D=45,8 KN: tractor 7t; trailer 14t

Rev. 00	Date	02/11/2017	By	V.Ca
Rev. 01	Date		By	
Rev. 02	Date		By	
Rev. 03	Date		By	
Rev. 04	Date		By	
Rev. 05	Date		By	

TOLLERANZE GENERALI SENZA INDICAZIONE
General tolerances unless specified
UNI EN 22768-1 - GRADO / grade m



TAVERNOLE SUL
MELLA (BS)

DIMENSIONI IN mm	SCALA	MATERIALE
Dimensions in mm	scale	Material
DENOMINAZIONE - Name	CODICE	MASSA
OCCHIONE	Part number	6,499 kg
	Nome file:	
	30248.dft	

MODIFICARE SOLO CON CAD, facendo un CAD system only

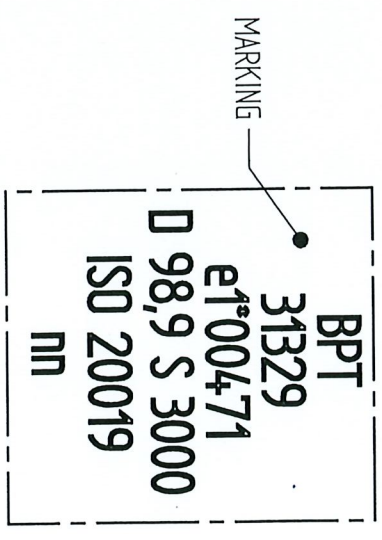
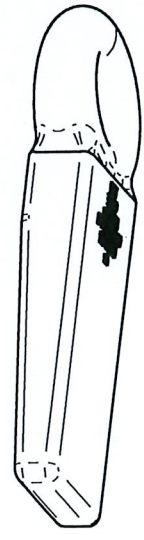
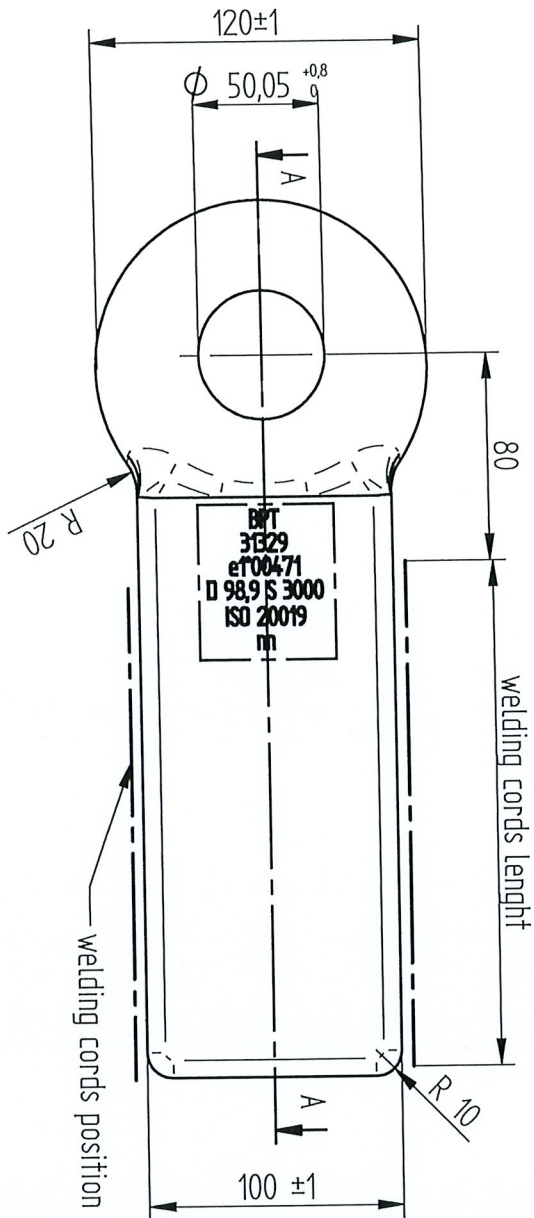

WELDING CORDS
SKETCH: dimension
a > 8 mm.

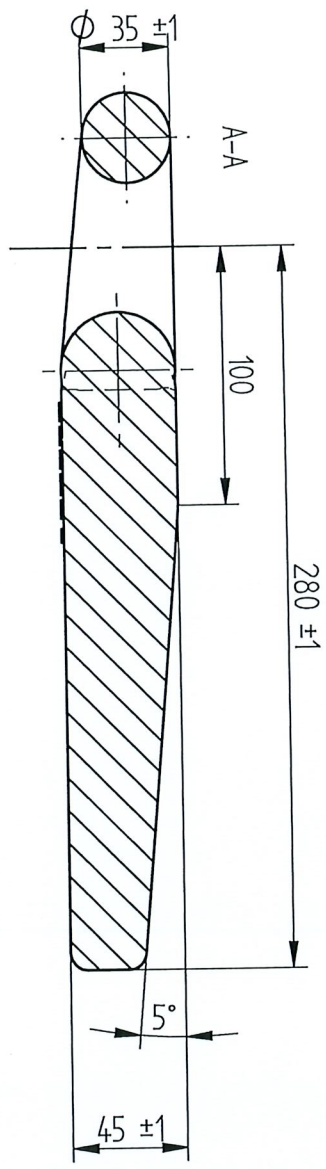
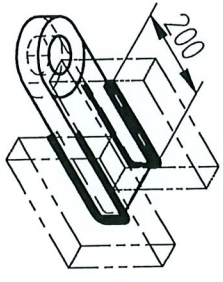

BPT ring eye 31329 is according to ISO 20019 norm.
 It shall used with follwing couplings:
 -) ISO 6489/1 ; -) ISO 6489/4 ;
TOWING CAPABILITY. Example for D=98,9 kN: tractor 14t; trailer 36t

Rev. 00 - Date - 02/02/2018 - By: V.Ca	Rev. ___ Date ___ By ___	TOLLERANZE GENERALI SENZA INDICAZIONE General tolerances unless specified
Rev. ___ Date ___ By ___	Rev. ___ Date ___ By ___	UNI EN 22768-1 - GRADO / grade m



DIMENSIONI IN mm Dimensions in mm	SCALA scale 1:2	MATERIALE Material	CODICE Part number	MASSA kg
DENOMINAZIONE - Name OCCHIONE BELGIO		30MnCrB5+QT	31329	9,428

Pos	P.N.	Description	Material	Qty
1	35225-L	Occhione Super Pesante Lav.	30MnCrB5+QT	1
2	35202	bussola pasante	EN S355 J0	1
3	35256	rondella per M52	EN C45	1
4	35227	Dado M52x5	Class 8.8	1
5	35210	Spina el. ISO 13337 - 8x80	Acciaio St	1

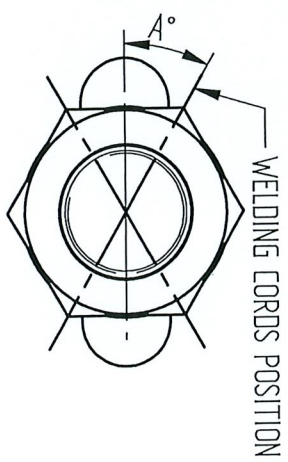
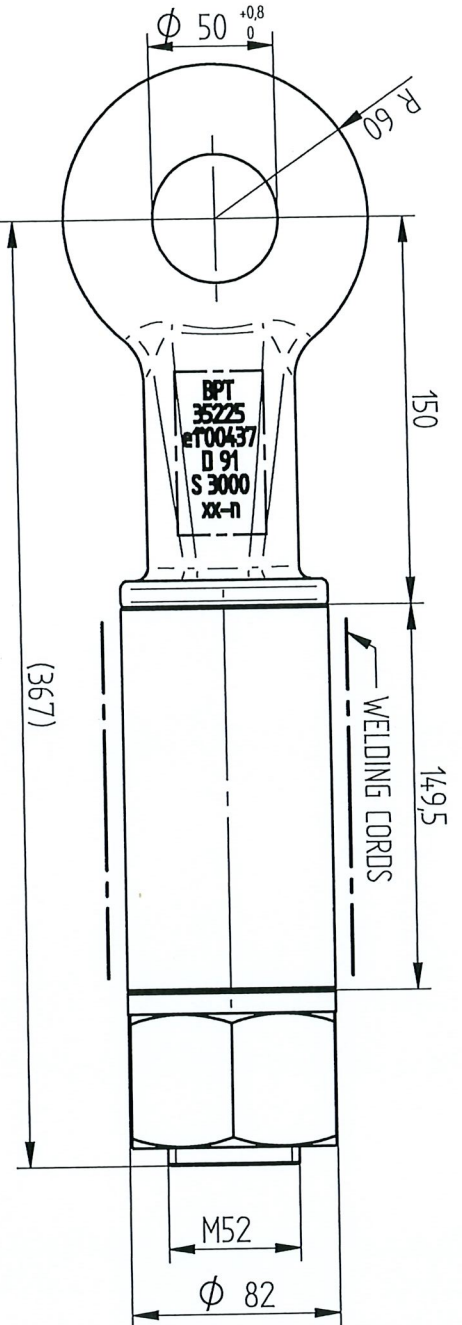
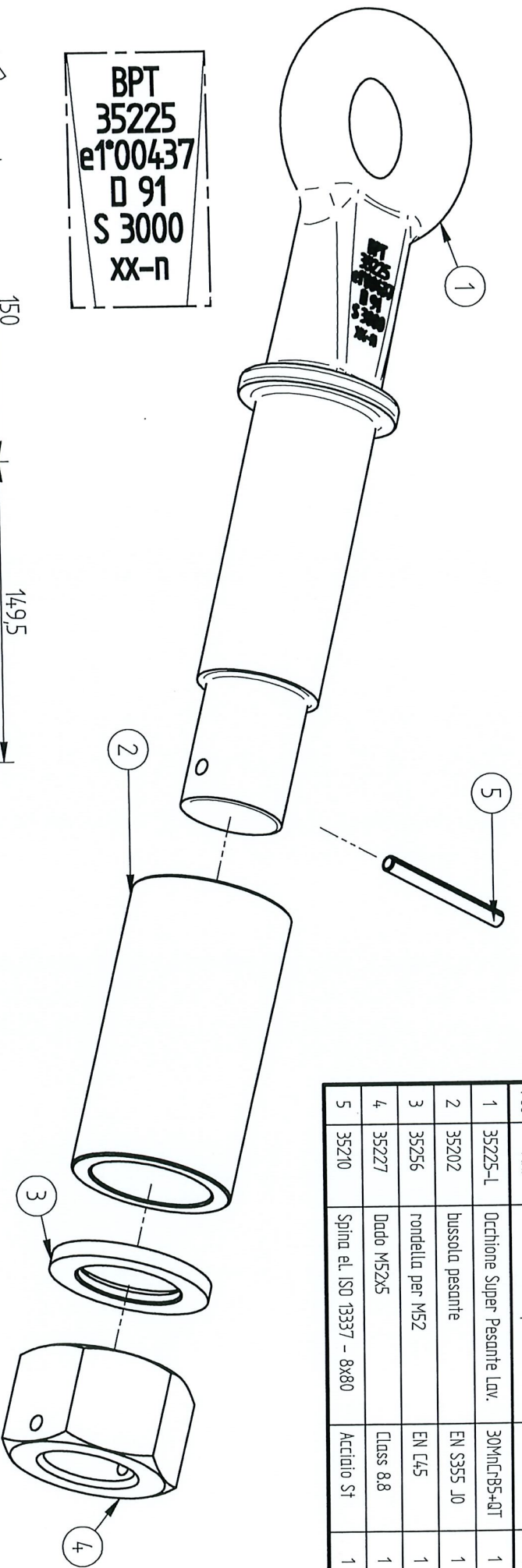

fix bushing trough nr 4 welding cords with $30^\circ < A < 45^\circ$, $a > 8\text{mm}$ and lenght $> 140\text{mm}$

BPT ring eye 35225 is according to ISO 5692/3 (shape Y) norm.
 It shall used with follwing couplings:
 -) ISO 6489/1 ; -) ISO 6489/4 ; -) ISO 6489/5 (SHAPE Y)
TOWING CAPABILITY. Example for D=91 KN: tractor 12,5t; trailer 36t

Rev. 00 - Date 20/11/2017 - By V.Cast	Rev. ___ Date _____ By ___	TOLLERANZE GENERALI SENZA INDICAZIONE
Rev. ___ Date _____ By ___	Rev. ___ Date _____ By ___	General tolerances unless specified
1	2	UNI EN 22788-1 - GRADO / grade m

bpu
TAVERNOLE SUL MELLA (BS)

DIMENSIONI IN mm
 Dimensions in mm

DENOMINAZIONE - Name
 Occhione Super Pesante

SCALA
 scale

MATERIALE
 Material

CODICE
 Part number

MASSA
 13,396 kg

Nome file: 35255.dft

MODIFICARE SOLO CON CAD. Handling on CAD system only

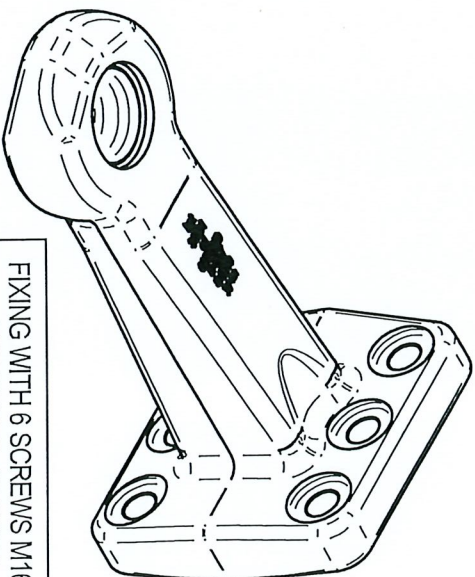
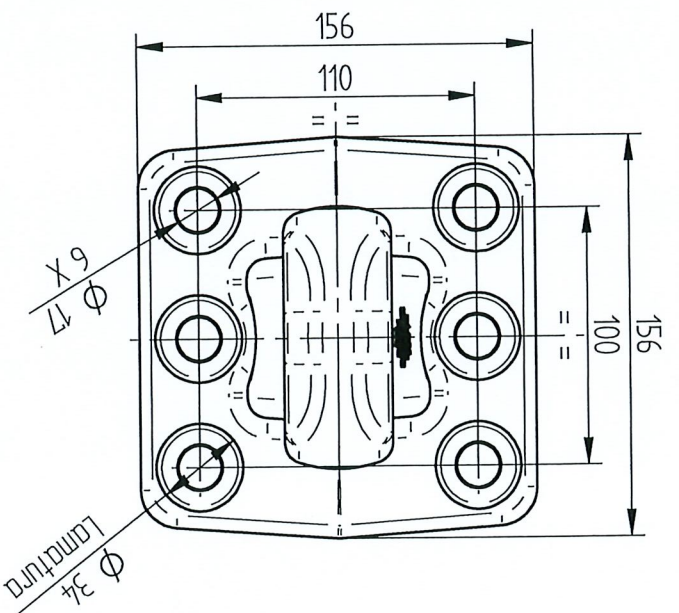
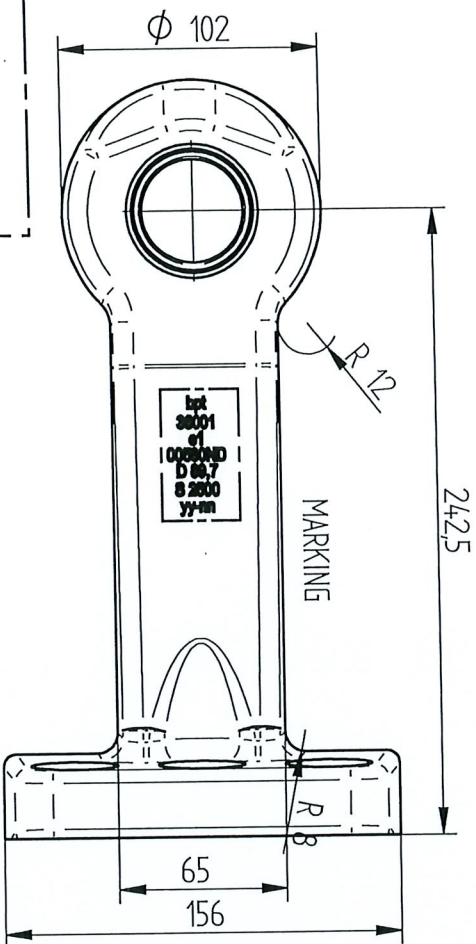
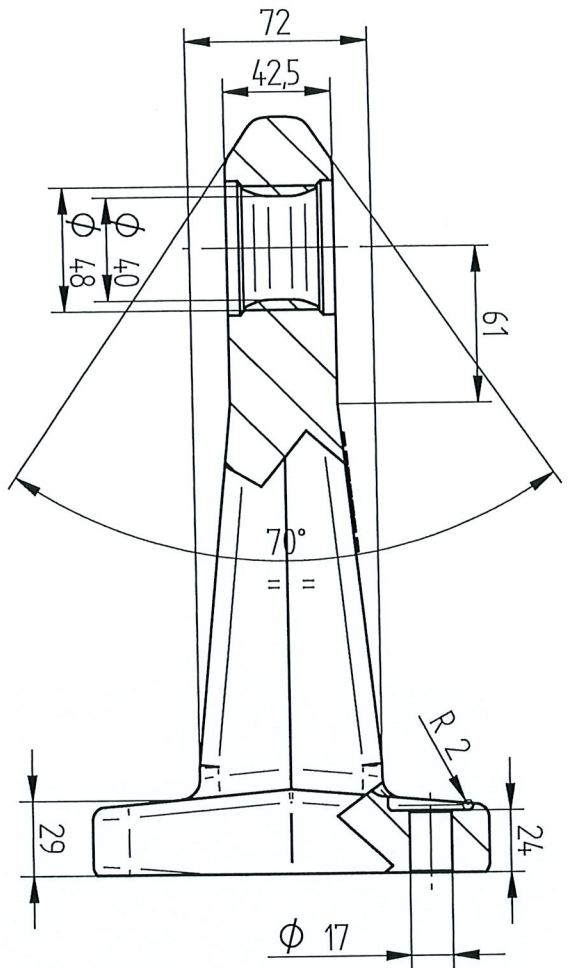

FIXING WITH 6 SCREWS M16-10.9
TIGHTENED AT 260 Nm

bpt
36001
@1
00580ND
D 89,7
S 2500
yy-nn

Marking

BPT ring eye 36001 is according to ISO 5692/2 (shape B) norm.
It shall used with couplings complying to ISO 6489/2 norm.
TOWING CAPABILITY.
Example for D=89,7 kN: tractor 12,5t; trailer 34t

Rev. 00 - Date - 01/12/2018 - By: V.Ca	Rev. _____ Date _____ By _____	TOLLERANZE GENERALI SENZA INDICAZIONE General tolerances unless specified
Rev. _____ Date _____ By _____	Rev. _____ Date _____ By _____	UNI EN 22768-1 - GRADO / grade m

bpt		DIMENSIONI IN mm	
TAVERNOLE SUL MELLA (BS)		SCALA	
COUPLING RING 5692-2+SOCKET		MATERIALE	
CODICE Part number		MATERIALE	
36001		36001	
MASSA		11,488 kg	
Nome file: 36001.dft			

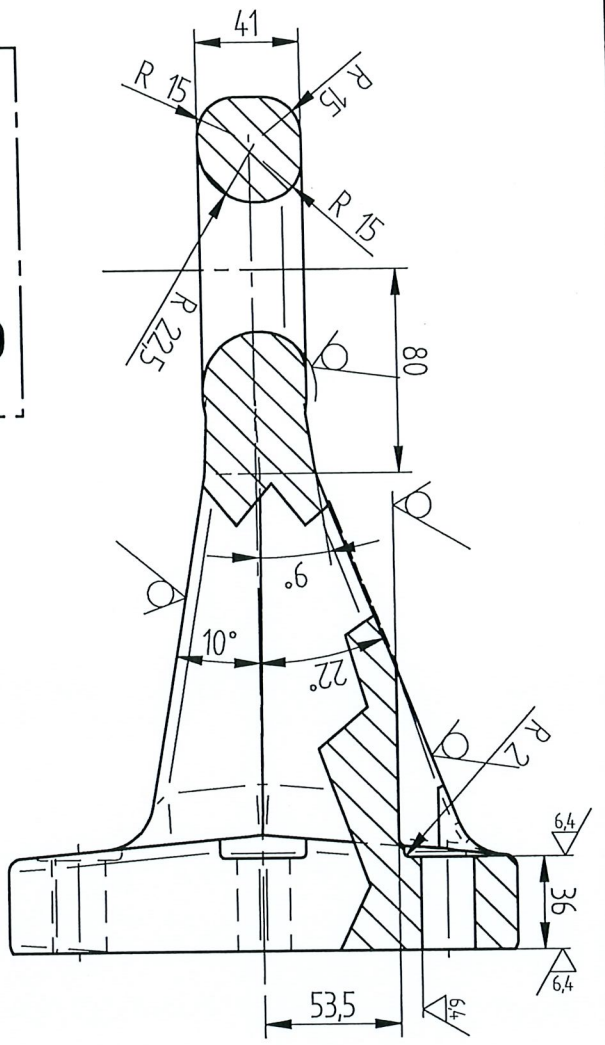

bpt
36020
e1
00591
D 100
S 3000
nn

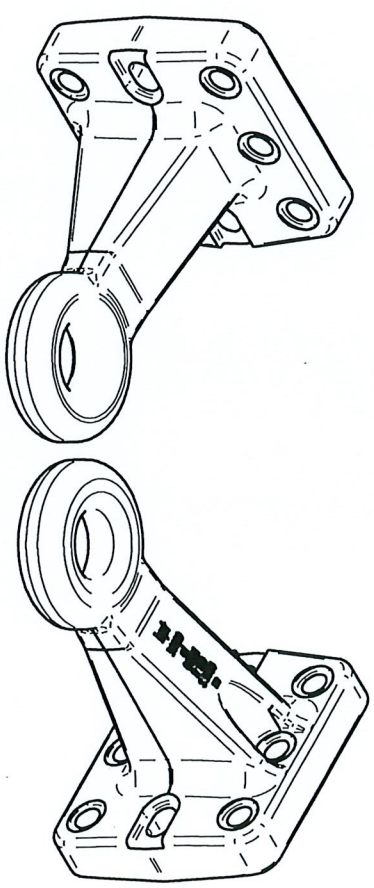
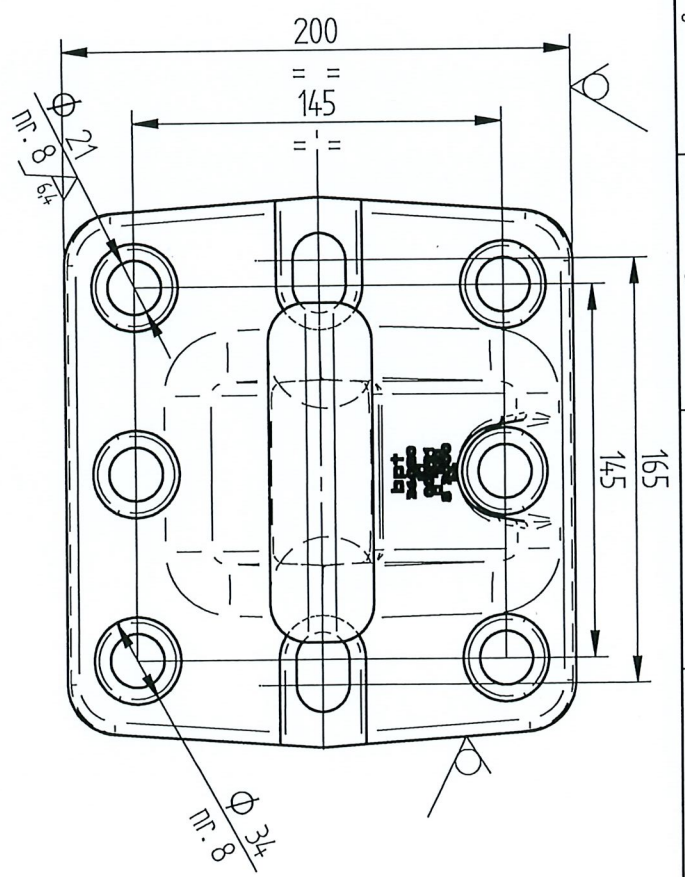
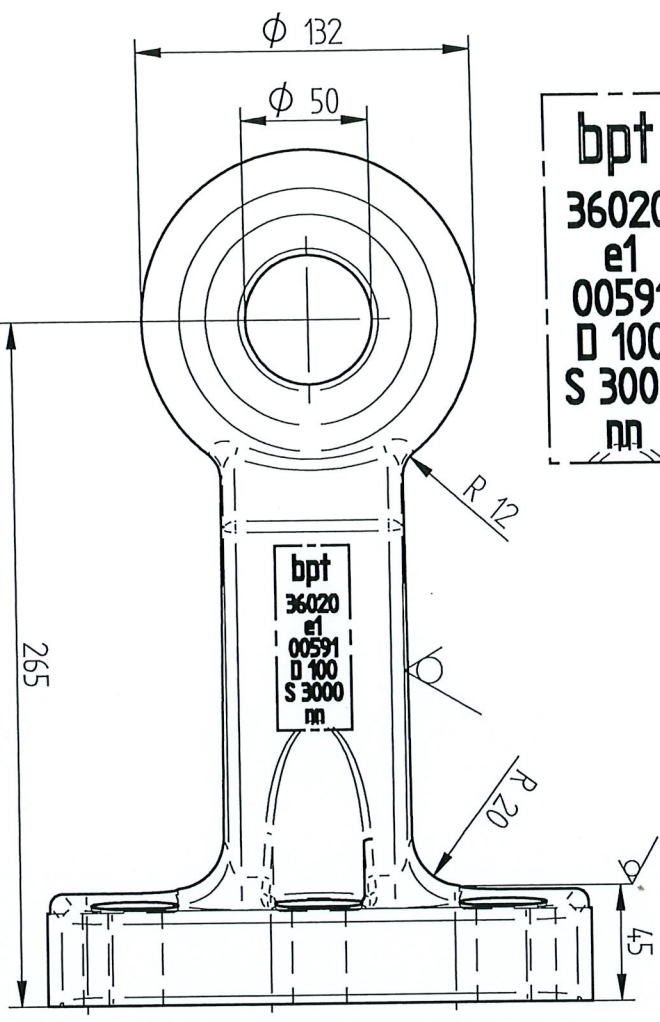

FIXING THROUGH 8 SCREWS M20-10.9
TIGHTENED AT 550 Nm

EXAMPLE FOR D=100 KN: TRACTOR = 14200 kg; TRAILER = 36000 kg

Rev. 00 - Date 09/01/2019 - By V.Ca	Rev. _____ Date _____ By _____	TOLLERANZE GENERALI SENZA INDICAZIONE General tolerances unless specified UNI EN 22768-1 - GRADO / grade m
-------------------------------------	--------------------------------	--

bpt		DIMENSIONI IN mm Dimensions in mm	SCALA scale	MATERIALE Material	CODICE Part number	MASSA Kg
TAVERNOLE SUL MELLA (BS)		DENOMINAZIONE - Name	OCCH. ISO 20019	EN 33MnCrBS+QT	36020	22,333 Kg
Nome file: 36020.dft						

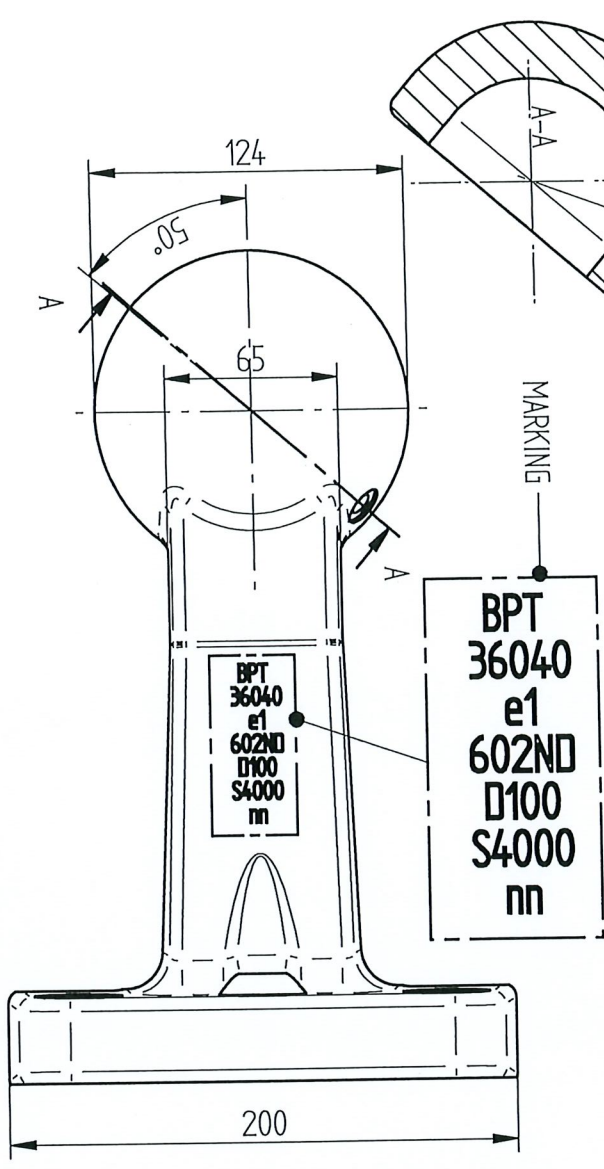
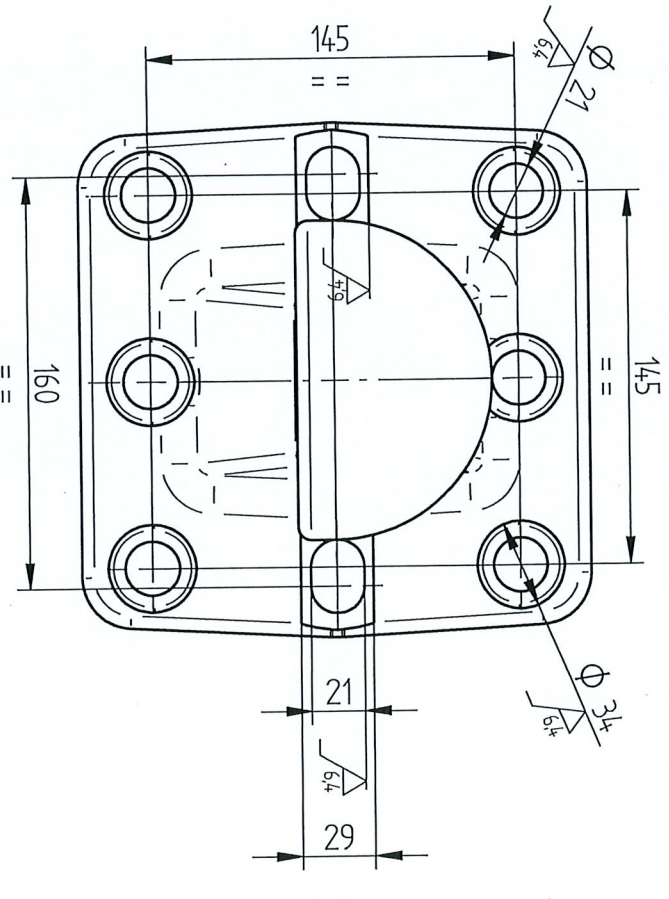
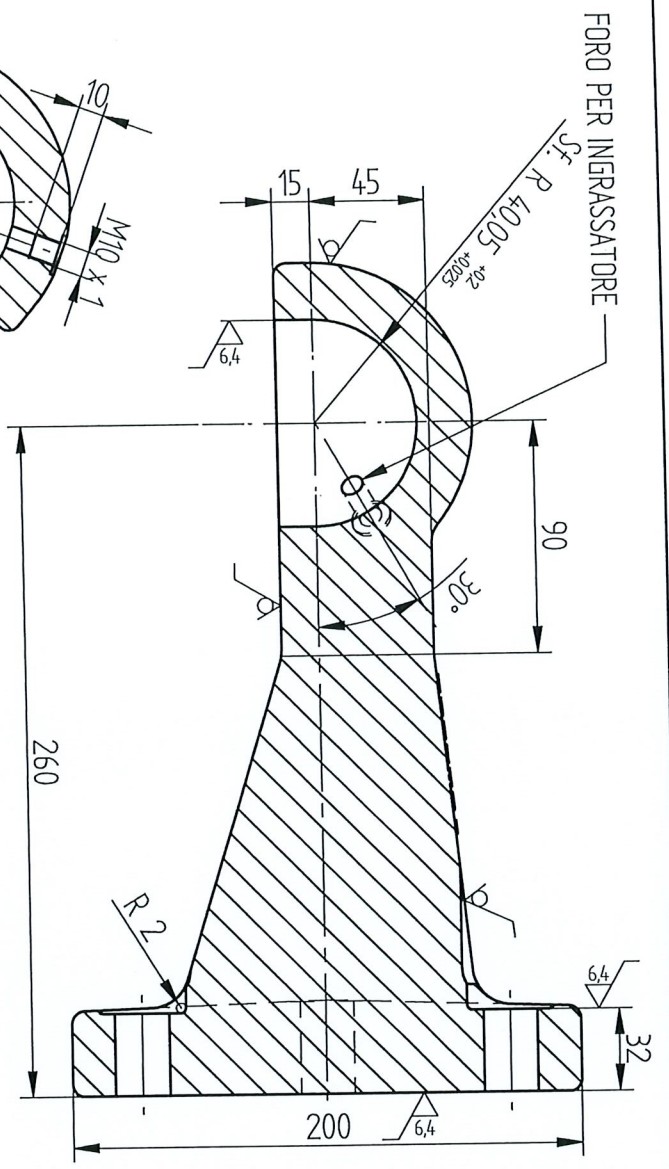

MARKING

BPT
36040
e1
602ND
D100
S4000
nn

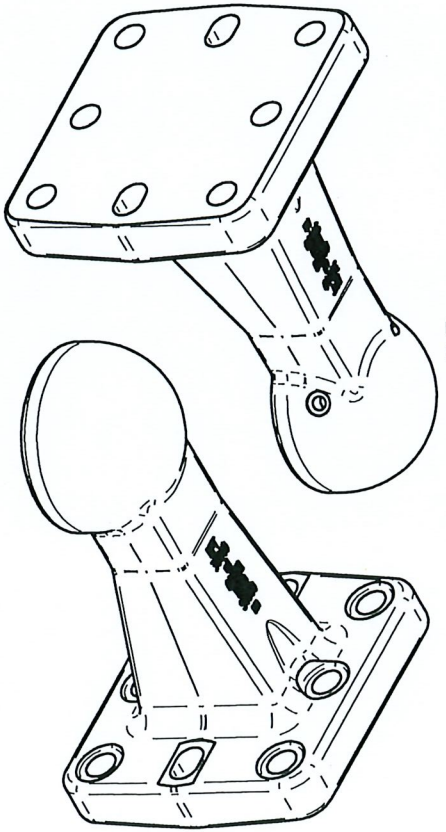

FIXING THROUGH 8 SCREWS M20-10.9
TIGHTEN AT 550 Nm

EXAMPLE FOR D=100 KN: TRACTOR = 13700 kg; TRAILER = 40000 kg

Rev. 00 - Date - 08/04/2019 - By: V.Ca	Rev. ___ Date _____ By _____	TOLLERANZE GENERALI SENZA INDICAZIONE General tolerances unless specified
Rev. ___ Date _____ By _____	Rev. ___ Date _____ By _____	UNI EN 22768-1 - GRADO / grade m

bpu		DIMENSIONI IN mm Dimensions in mm	
TAVERNOLE SUL MELLA (BS)		SCALA scale	
IS024347 - FLANGED-LAV		DENOMINAZIONE - Name	
CODICE Part number		MATERIALE Material	
36040		EN 33MnCrB5+QT	
MASSA 21,154 Kg		None file: 36040-LAV.dft	

MODIFICARE SOLO CON CAD. Handling on CAD system only

MARKING

BPT
36050
e1
652ND
D100
S4000
nn

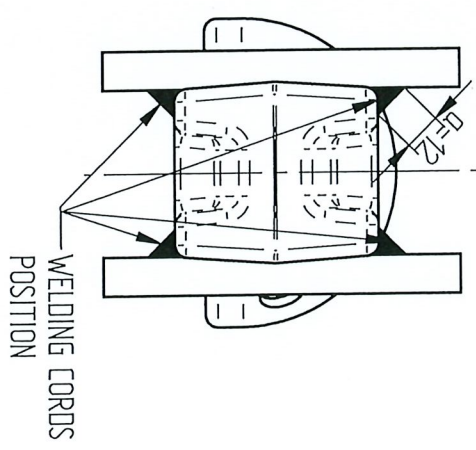
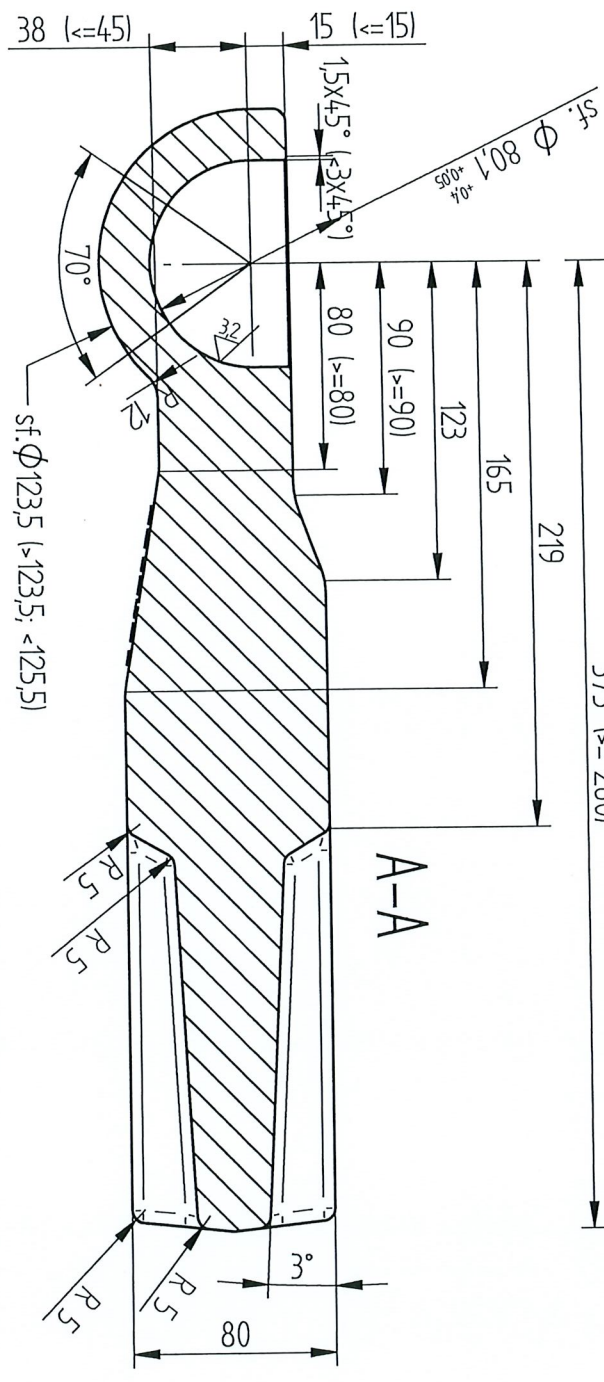
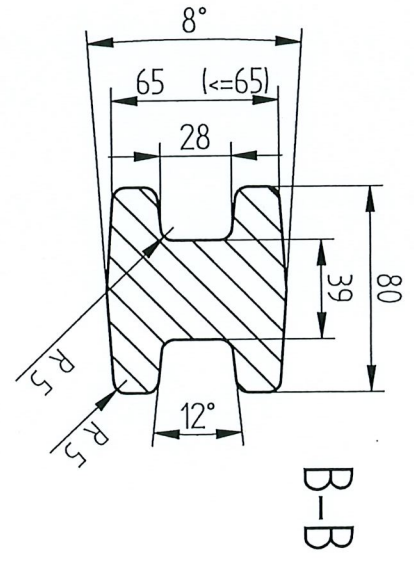
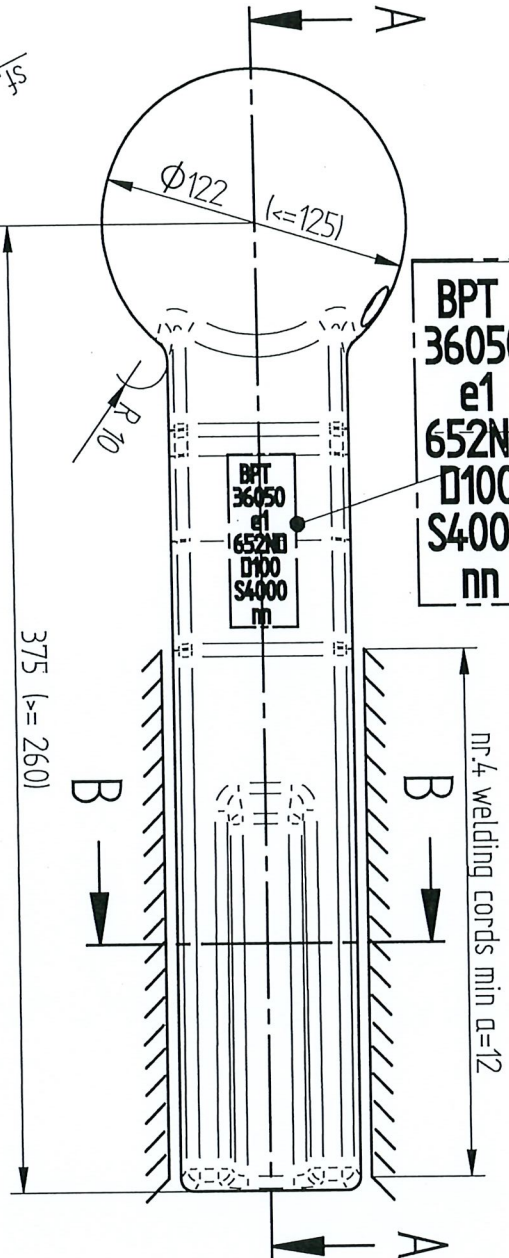

32
(V)

NB: between parenthesis dimensions prescribed by standard ISO 24347:2005

Rev. 00 - Date - 03/09/2019 - By: V.Ca	Rev. _____ Date _____ By _____	TOLLERANZE GENERALI SENZA INDICAZIONE General tolerances unless specified UNI EN 22768-1 - GRADO / grade m
--	--------------------------------	--

	DIMENSIONI IN mm	SCALA	MATERIALE	MASSA
	Dimensions in mm	scale	Material EN 34L N104	14,358 kg
DENOMINAZIONE - Name		CODICE		
Dcch. sfera 80		Part number		
		36050		
		36050dft		

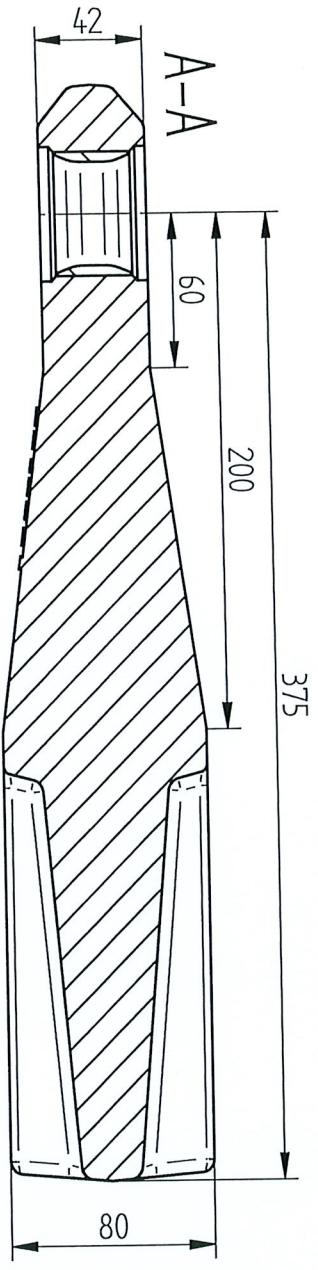
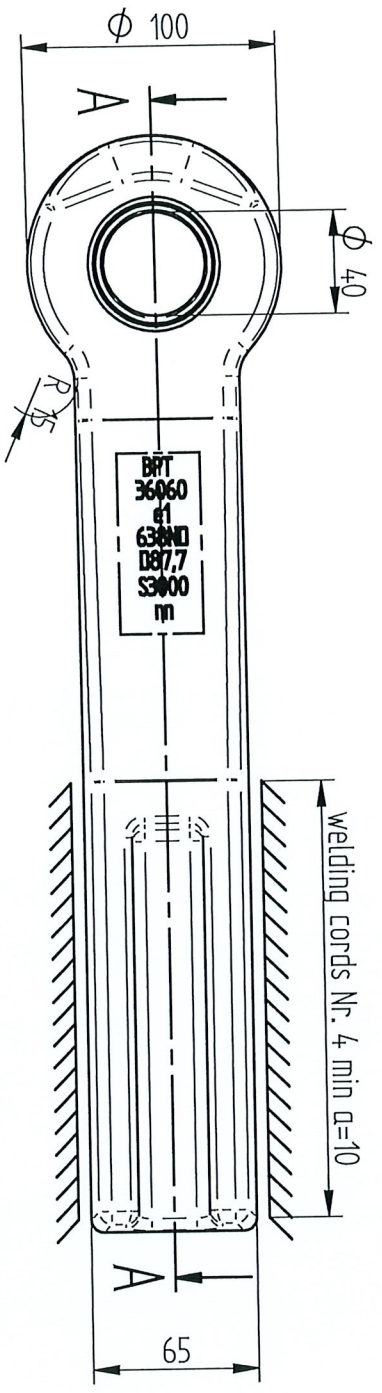

marking

BPT
36060
e1
638ND
D87,7
S3000
m

BPT ring eye 36060 is according to ISO 5692-2 norm.
TOWING CAPABILITY. Example for D=87,7KN: tractor 12t, trailer 35t
It shall used with couplings ISO 6489-2 and ISO 6489-3 cat.1 and 2

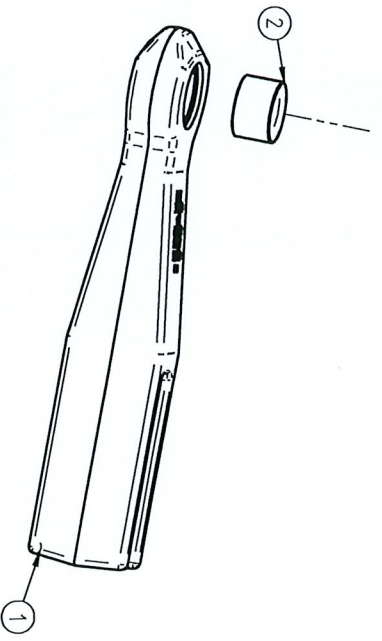
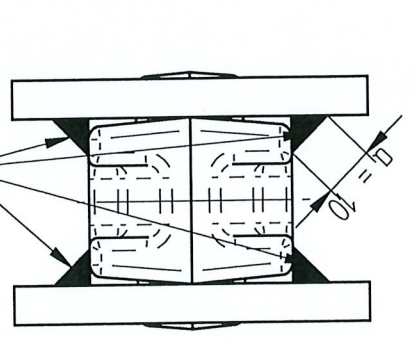

Pos	Part Numbl.	Material	Qty
1	36060	EN33MnCrBS+QT	1
2	36010	EN42CrNiMo4+QT	1

DIMENSIONI IN mm
Dimensions in mm

DENOMINAZIONE - Name

SCALA
scale

MATERIALE
Material

CODICE
Part number

MASSA
kg

bpu
TAVERNOLE SUL
MELLA (BS)

Docch. ISO 5692-2

36060

11510 kg

Rev. 00 - Date - 20/08/2019 - By: V.Ca
Rev. ___ Date ___ By ___
TOLLERANZE GENERALI SENZA INDICAZIONE
General tolerances unless specified
UNI EN 22768-1 - GRADO / grade m

Home file: 35060-ASSY.dft
MODIFICARE SOLO CON CAD. Handing in CAD system only

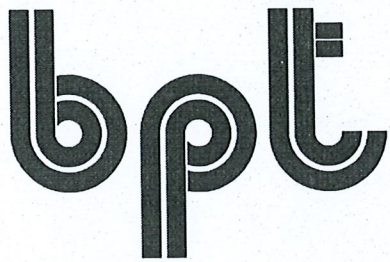

BATTISTA PORTERI S.R.L.

Via Statale 13

25060 Tavernole sul Mella (Brescia) ITALIA

Tel. 030/920131-920061-Fax 030/920783

COD.

32424

OCCHIONE DANIMARCA
(6002)

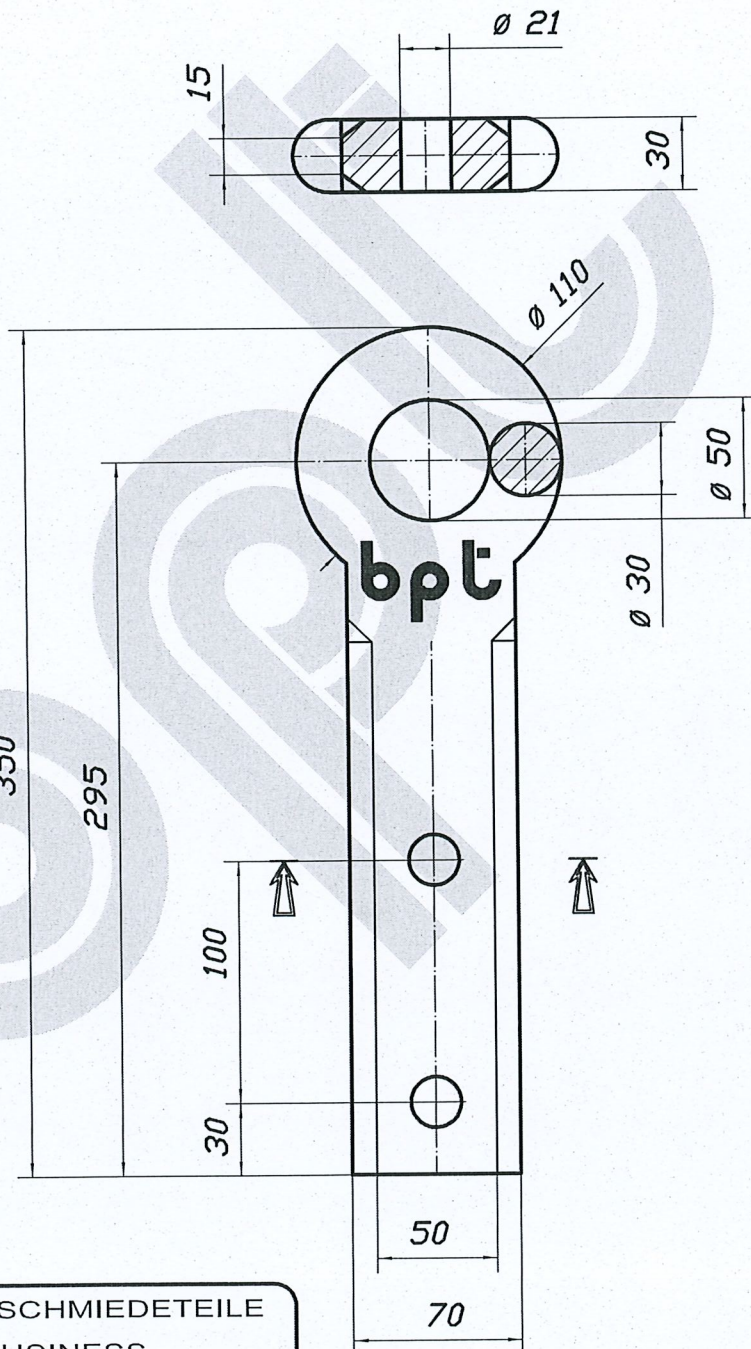

WIR FERTIGEN GESENKSCHMIEDETEILE
DROP FORGING OUR BUSINESS
NOUS ESTAMPONS TOUS LES ACIERS
NOI STAMPIAMO L'ACCIAIO

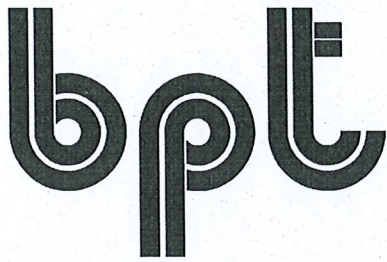

BATTISTA PORTERI S.R.L.

Via Statale 13

25060 Tavernole sul Mella (Brescia) ITALIA

Tel. 030/920131-920061-Fax 030/920783

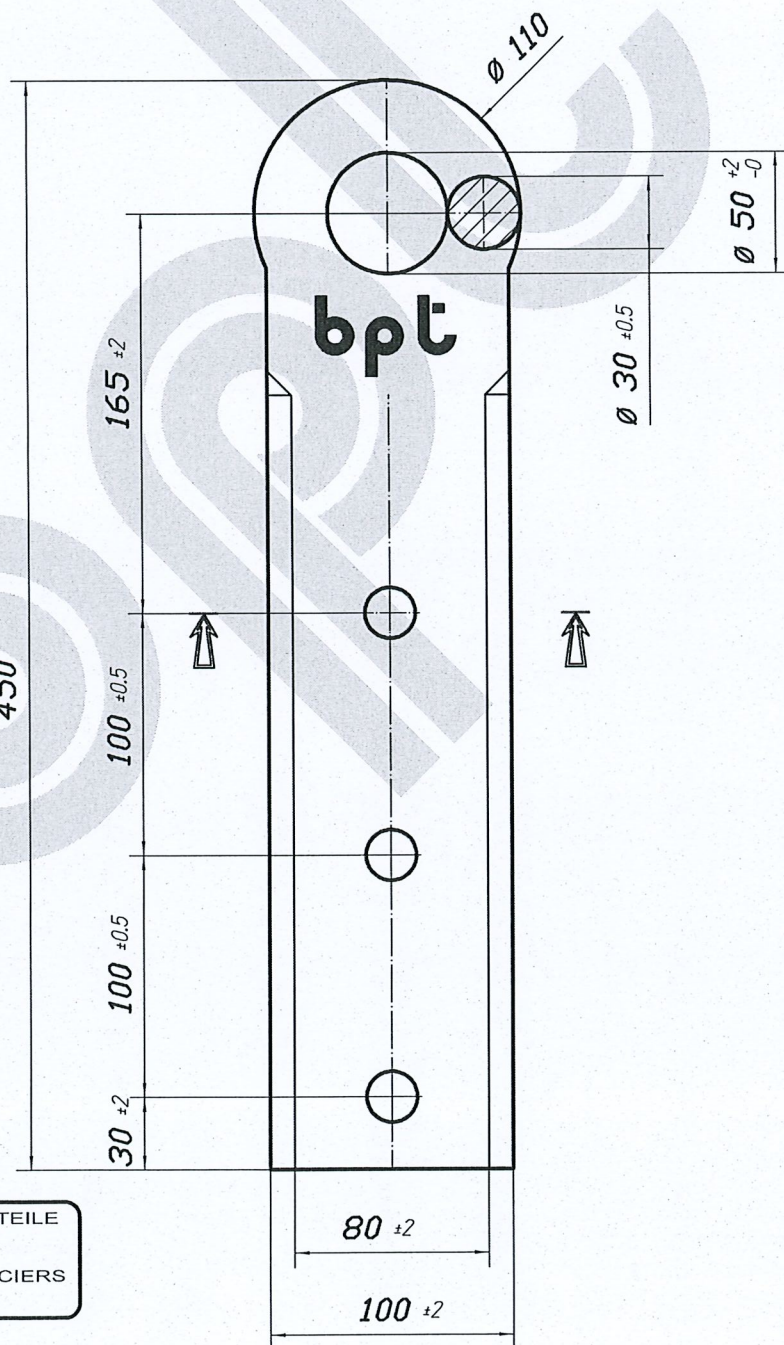
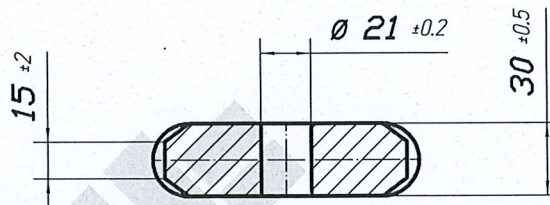

COD.
32425

OCCHIONE DANIMARCA
3 FORI

WIR FERTIGEN GESENKSCHMIEDETEILE
DROP FORGING OUR BUSINESS
NOUS ESTAMPONS TOUS LES ACIERS
NOI STAMPIAMO L'ACCIAIO

bpt

BATTISTA PORTERI S.R.L.

Via Statale 13

25060 Tavernole sul Mella (Brescia) ITALIA

Tel. 030/920131-920061-Fax 030/920783

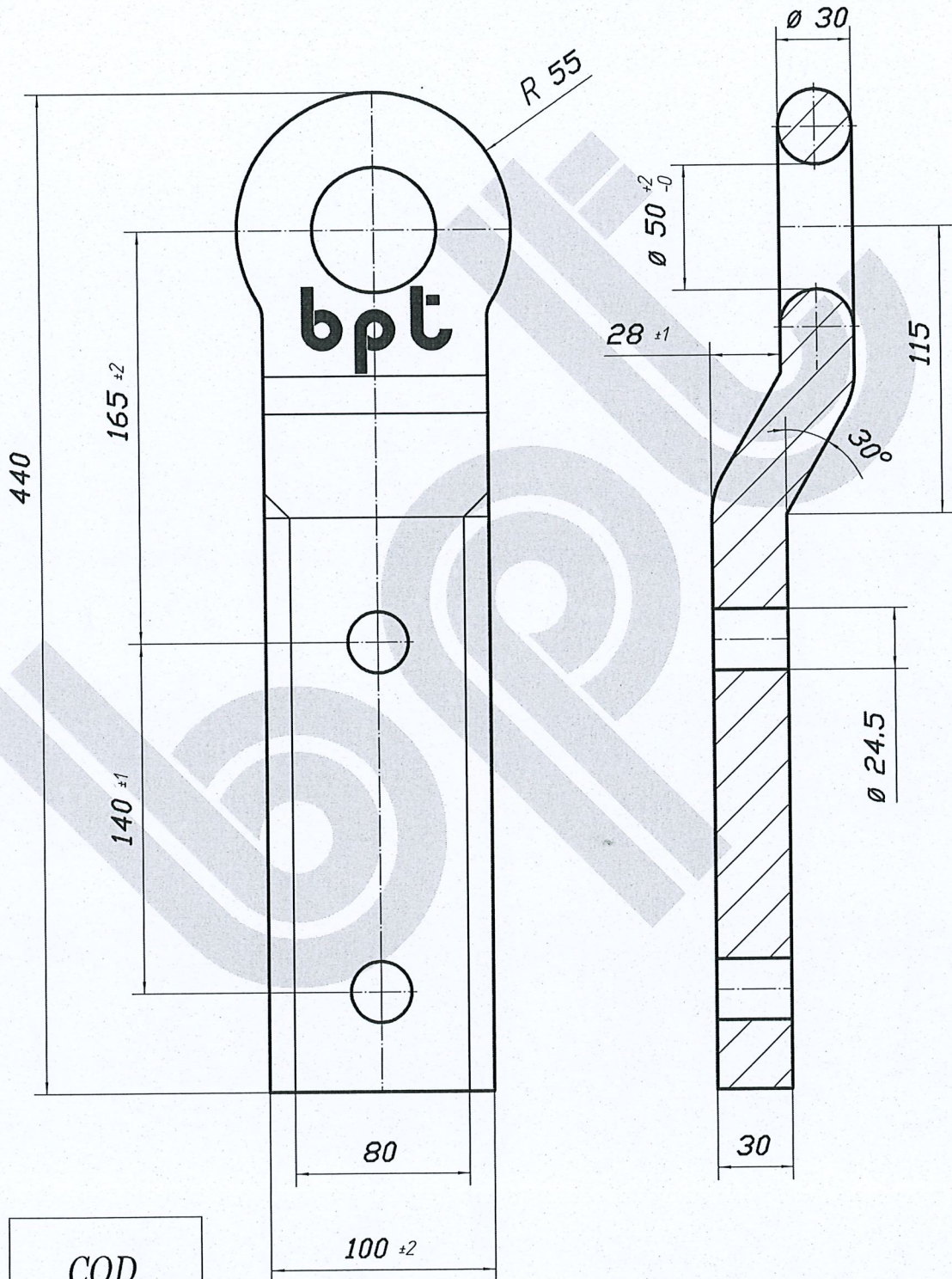

COD.

32425/CK

OCCHIONE DANIMARCA PIEGATO

WIR FERTIGEN GESENKSCHMIEDETEILE
DROP FORGING OUR BUSINESS
NOUS ESTAMPONS TOUS LES ACIERS
NOI STAMPIAMO L'ACCIAIO



BATTISTA PORTERI S.R.L.

Via Statale 13

25060 Tavernole sul Mella (Brescia) ITALIA

Tel. 030/920131-920061-Fax 030/920783

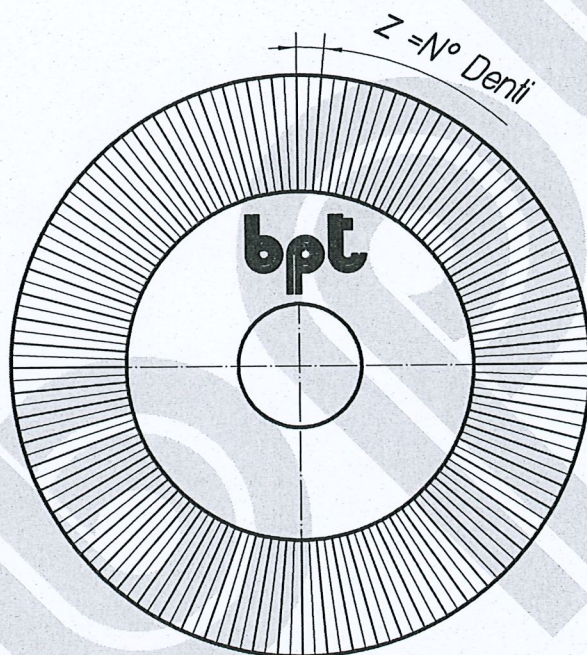
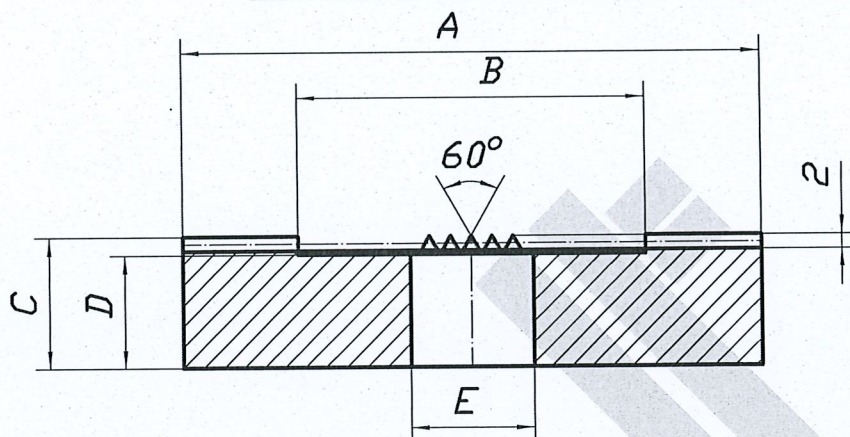

CORONE DENTATE REGOLAZIONE

COD.	$\varnothing A$	$\varnothing B$	C	D	$\varnothing E$	Z
14450	50	25	17	14.5	17	40
14480	80	48	18	15.5	-	72

WIR FERTIGEN GESENKSCHMIEDETEILE
 DROP FORGING OUR BUSINESS
 NOUS ESTAMPONS TOUS LES ACIERS
 NOI STAMPIAMO L'ACCIAIO

bpt

BATTISTA PORTERI S.R.L.

Via Statale 13

25060 Tavernole sul Mella (Brescia) ITALIA

Tel. 030/920131-920061-Fax 030/920783

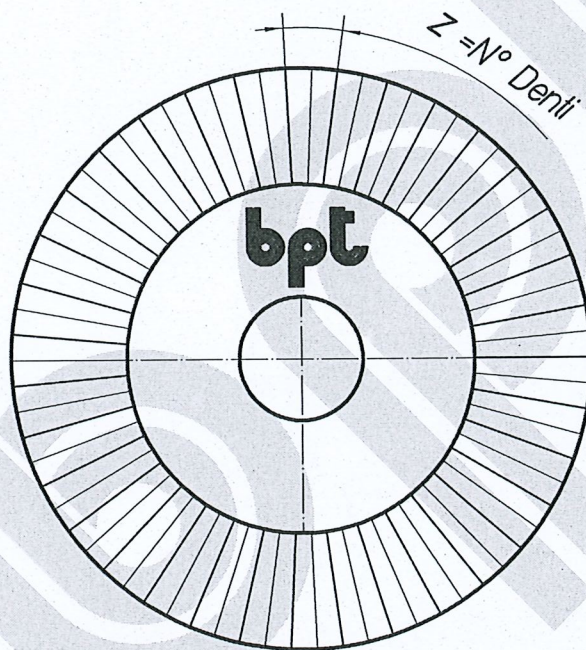
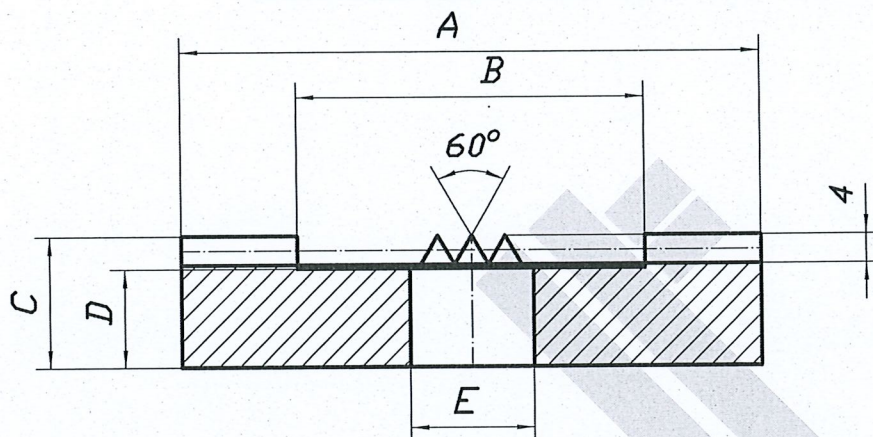

CORONE DENTATE REGOLAZIONE

COD.	\varnothing A	\varnothing B	C	D	\varnothing E	Z
14465	65	36	20	14	17	21
14490	90	58	20	14	17	35

WIR FERTIGEN GESENKSCHMIEDETEILE
 DROP FORGING OUR BUSINESS
 NOUS ESTAMPONS TOUS LES ACIERS
 NOI STAMPIAMO L'ACCIAIO

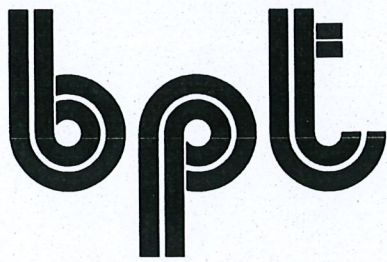

BATTISTA PORTERI S.R.L.

Via Statale 13

25060 Tavernole sul Mella (Brescia) ITALIA

Tel. 030/920131-920061-Fax 030/920783

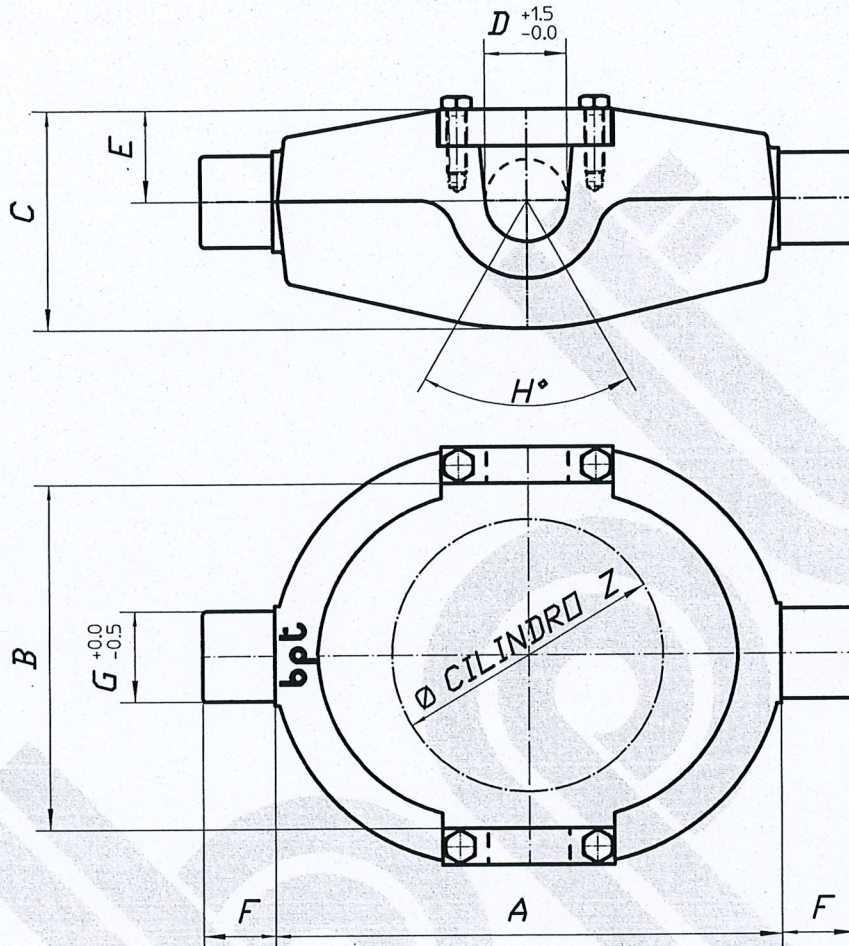

CULLE PER RIBALTABILE PER MOVIMENTO TRILATERALE
 CRALDES FOR TREE-SIDE DUMPERS
 BERCEAUX POUR BENNES A BASCULEMENT TRILATERALE

COD.	TIPO	A	B	C	øD	E	F	øG	H	L	øZ	PESO KG
31201	1	200	120	77	35	25	35	35	65°		95	5,5
31352	2	230	135	94	35	27	40	40	75°		112	7,8
31553	3	230	155	110	40	30	40	40	65°		125	9,5
31854	4	280	180	120	45	50	40	50	60°		150	13,2
32015	5	320	200	140	50	50	45	50	60°		168	23

WIR FERTIGEN GESENKSCHMIEDETEILE
 DROP FORGING OUR BUSINESS
 NOUS ESTAMPONS TOUS LES ACIERS
 NOI STAMPIAMO L'ACCIAIO

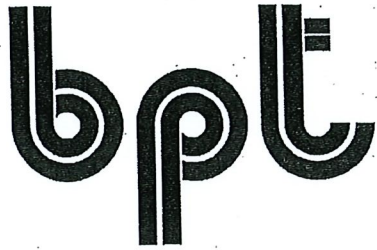

BATTISTA PORTERI S.R.L.

Via Statale 13
25060 Tavernole sul Mella (Brescia) ITALIA
Tel. 030/920131-920061-Fax 030/920783

WIR FERTIGEN GESENKSCHMIEDETEILE
DROP FORGING OUR BUSINESS
NOUS ESTAMPONS TOUS LES ACIERS
NOI STAMPIAMO L'ACCIAIO

COMPLESSIVO SFERA Ø75 PER RIBALTABILI port. Max Kg.6.000

Ensemble de sphere Ø75 portée Maxi Kg.6.000

Dumper Ø75 ball assembly Max capacity load Kg.6.000

Kugelsatz Ø75 für kippwagen Max tragkraft Kg.6.000

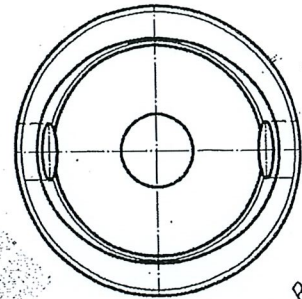

R 37.5 Sferico

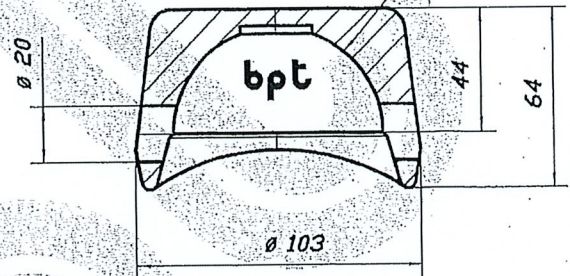

COD.	PESO KG	I	SUPPORTO SFERA Ø75 BASSO
		F	Palier de sphère Ø75
33053	1.650	GB	LOW SOCKET Ø75
		D	Kugelhalter Ø75

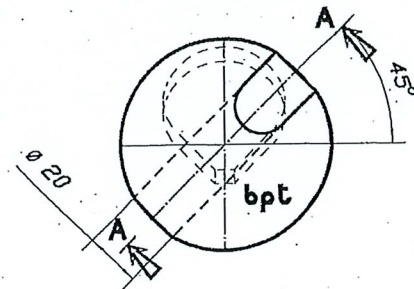
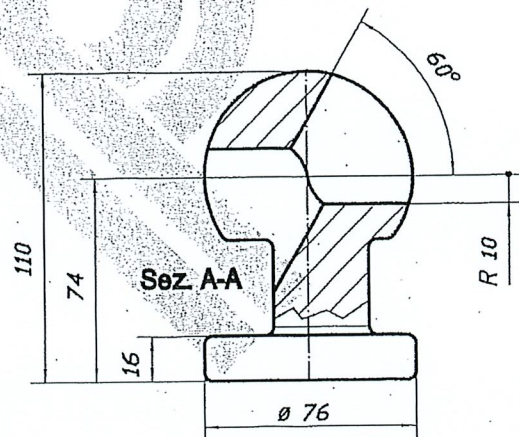
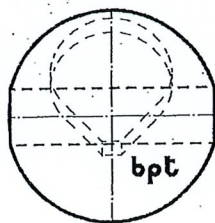
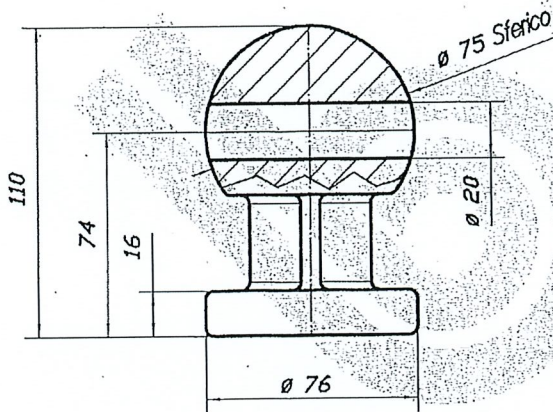

COD.	PESO KG	I	SFERA POSTERIORE Ø75 CON FORO
		F	Sphère latérale avec trou Ø80
33055	2.200	GB	Ø80 Lateral ball with hole
		D	Seiliche kugel Ø80 mit Bohrung

COD.	PESO KG	I	SFERA POSTERIORE Ø75 CON ASOLA
		F	Sphère arrière Ø75
33056/DX 33056/SX	2000	GB	Ø80 Rear ball with slot
		D	Hintere kugel Ø80 mit Öse

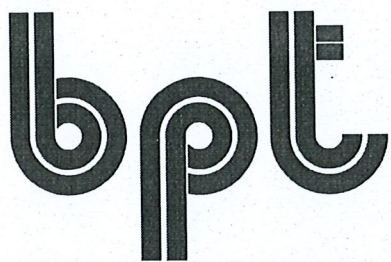

BATTISTA PORTERI S.R.L.

Via Statale 13
25060 Tavernole sul Mella (Brescia) ITALIA
Tel. 030/920131-920061-Fax 030/920783

WIR FERTIGEN GESENKSCHMIEDETEILE
DROP FORGING OUR BUSINESS
NOUS ESTAMPONS TOUS LES ACIERS
NOI STAMPIAMO L'ACCIAIO

COMPLESSIVO SFERA Ø80 PER RIBALTABILI port. Max Kg.10.000

Ensemble de sphere Ø80 portee Maxi Kg.10.000

Dumper Ø80 ball assembly Max capacity load Kg.10.000

Kugelsatz Ø80 für kippwagen Max tragkraft Kg.10.000

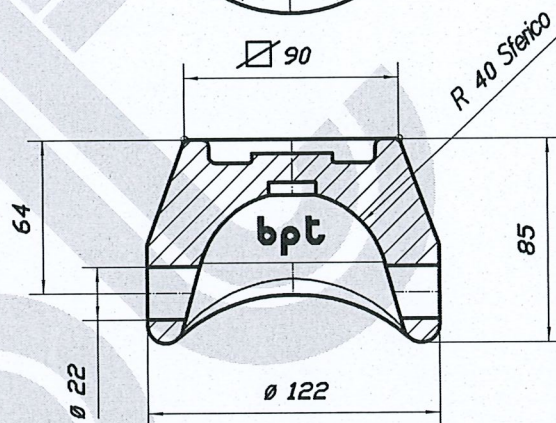
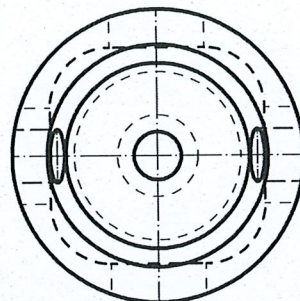

COD.	PESO KG	I	SUPPORTO SFERA Ø80
		F	Palier de sphere Ø80
33061	4.700	GB	Ø80 Ball support
		D	Kugelhalter Ø80

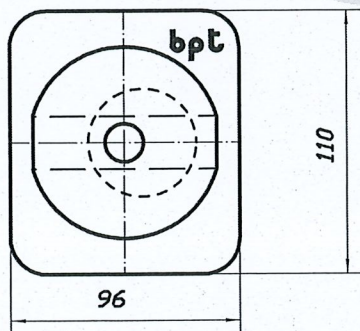
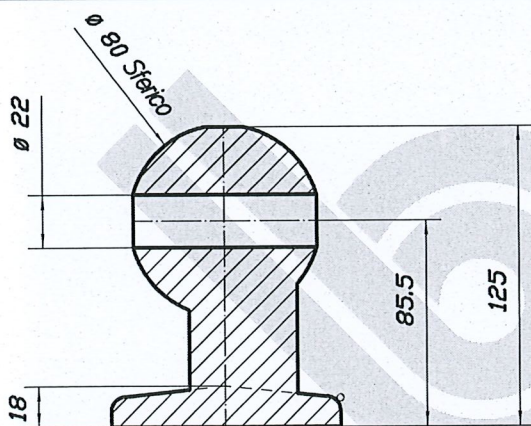

COD.	PESO KG	I	SFERA LATERALE Ø80 CON FORO
		F	Sphère latérale avec trou Ø80
33062	3.450	GB	Ø80 Lateral ball with hole
		D	Seiliche kugel Ø80 mit Bohrung

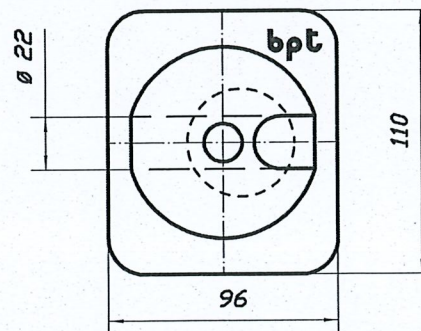
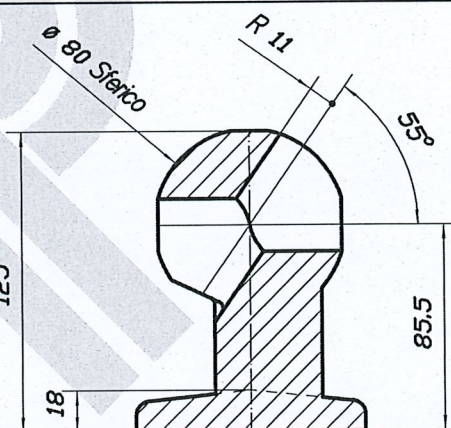

COD.	PESO KG	I	SFERA POSTERIORE Ø80 CON ASOLA
		F	Sphère arrière Ø80 G et D
33063	3.150	GB	Ø80 Rear ball with slot
		D	Hintere kugel Ø80 mit Öse

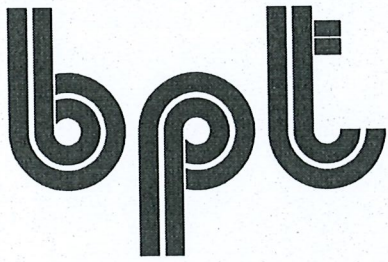

BATTISTA PORTERI S.R.L.

Via Statale 13

25060 Tavernole sul Mella (Brescia) ITALIA

Tel. 030/920131-920061-Fax 030/920783

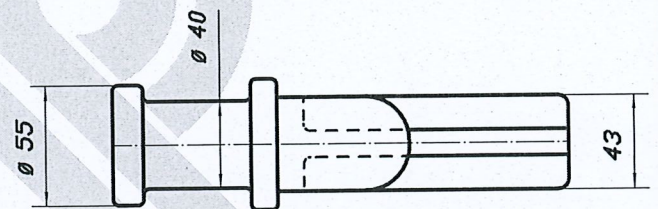
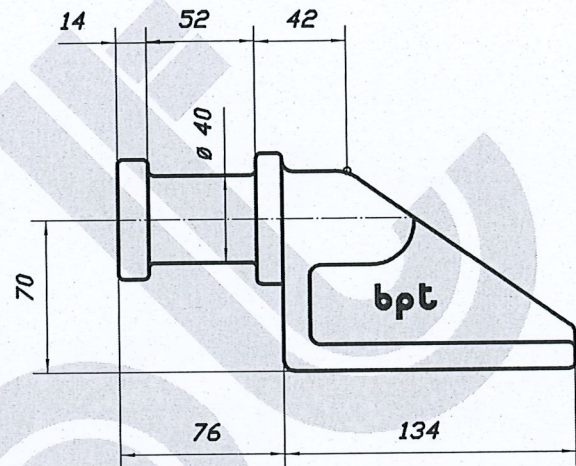
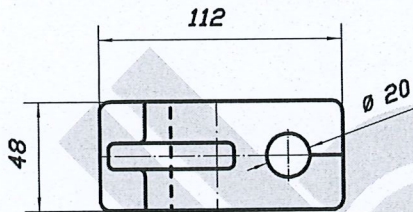
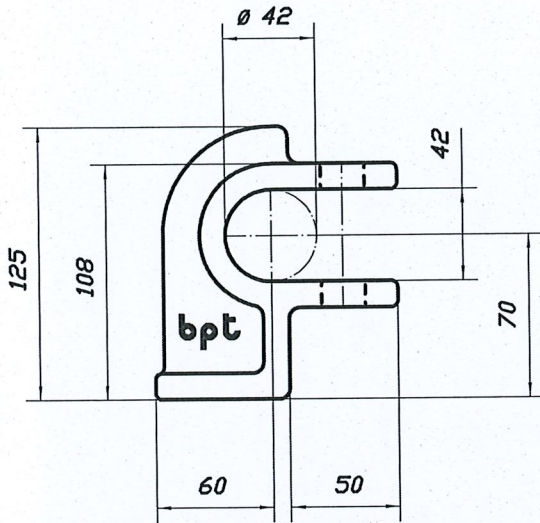

COD.	I	TESTINA Ø40 TIPO DOUMPER	COD.	I	PIANTONE Ø40 TIPO DOUMPER
	F	Palier fixe renforce' Ø40		F	Pivot de ridelle Ø40
90030	GB	Doumper strengthened catch Ø40	90031	GB	Column Ø40
	D	Verstaerker verschluss Ø40 typ doumper		D	Haltenocken Ø40

WIR FERTIGEN GESENKSCHMIEDETEILE
 DROP FORGING OUR BUSINESS
 NOUS ESTAMPONS TOUS LES ACIERS
 NOI STAMPIAMO L'ACCIAIO

bpt

BATTISTA PORTERI S.R.L.

Via Statale 13

25060 Tavernole sul Mella (Brescia) ITALIA

Tel. 030/920131-920061-Fax 030/920783

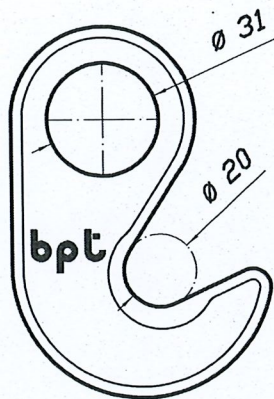

GANCIO PER CERNIERA

COD.

30780

PIASTRA PER CERNIERA
RIBALTABILE

COD.

30790

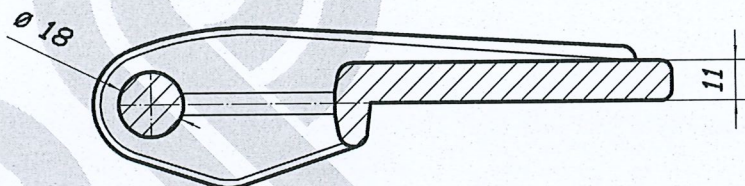
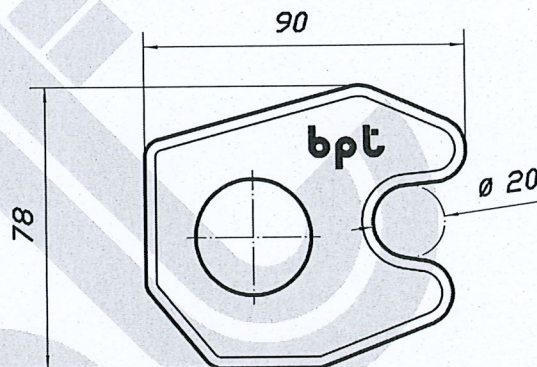
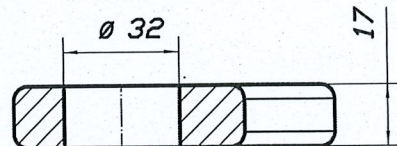

CERNIERA SOTTOSOPRA
PER RIBALTABILE

COD.

30770

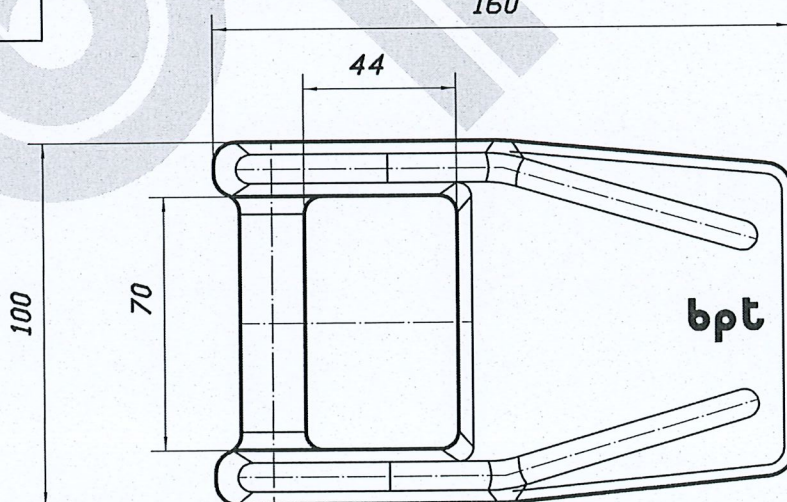

WIR FERTIGEN GESENKSCHMIEDETEILE
DROP FORGING OUR BUSINESS
NOUS ESTAMPONS TOUS LES ACIERS
NOI STAMPIAMO L'ACCIAIO

bpt

BATTISTA PORTERI S.R.L.

Via Statale 13

25060 Tavernole sul Mella (Brescia) ITALIA

Tel. 030/920131-920061-Fax 030/920783

COD.
35051

MASCHIO PIANTONE COPIA VITE M22
LIGHT MALE PANT M22
LEICHTE RUNGENKEILE M22
SERIE LÉGÈRE MÂLE M22

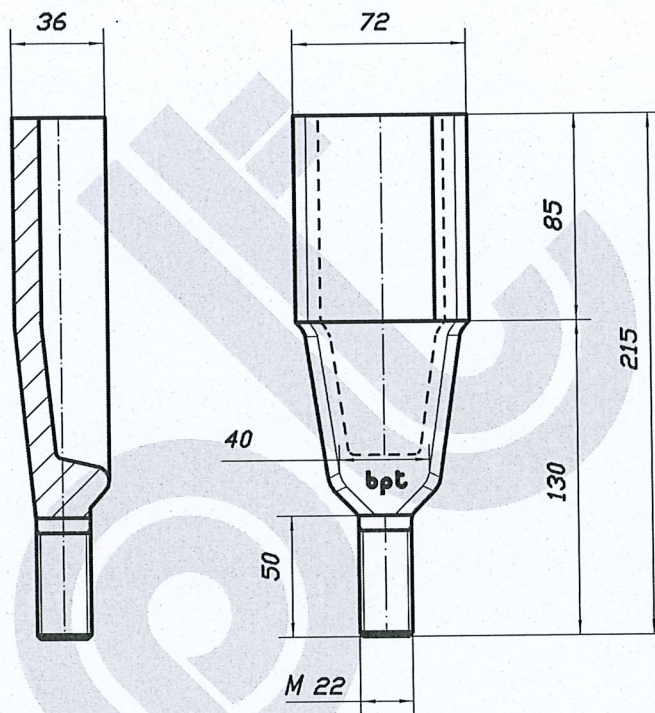

COD.
35052

FEMMINA PIANTONE COPIA VITE PICCOLO
LIGHT FEMALE SOCKET xM22
RUNGENTASCHE LEICHTE
FEME DE PIED DE RANCHER LÉGÈRE

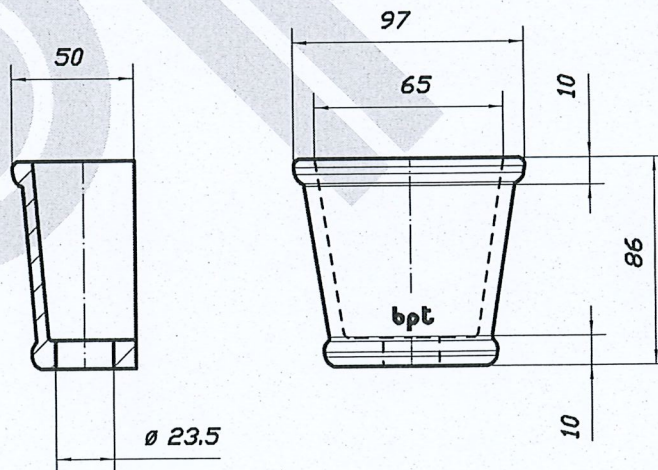

WIR FERTIGEN GESENKSCHMIEDETEILE
DROP FORGING OUR BUSINESS
NOUS ESTAMPONS TOUS LES ACIERS
NOI STAMPIAMO L'ACCIAIO

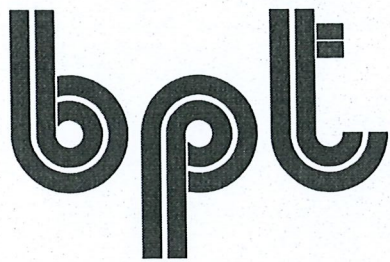

BATTISTA PORTERI S.R.L.

Via Statale 13

25060 Tavernole sul Mella (Brescia) ITALIA

Tel. 030/920131-920061-Fax 030/920783

COD.

35054

MASCHIO COLONNETTA M24
SCHWERE RUNGENKTEILE M24
HAEVY DUTY MALE PART M24
RENFORCÉE MÂLE M24

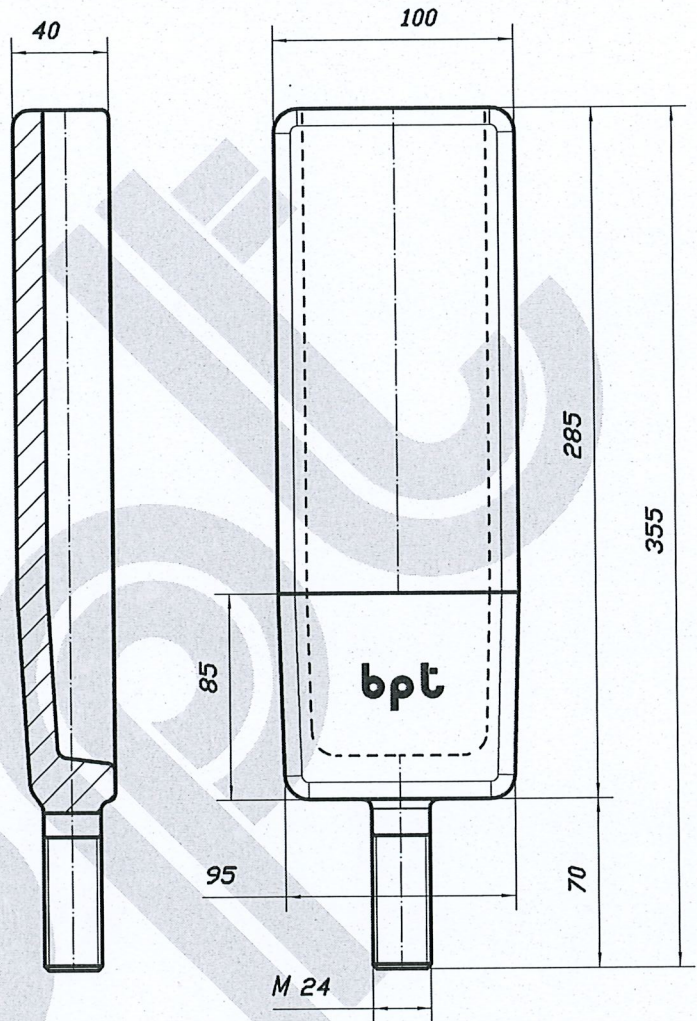

COD.

35053

FEMMINA COLONNETTA M24
SCHWERE RUNGENTASCHE M24
HAEVY DUTY FEMALE PART M24
RENFORCÉE PIED DE RANCHER TROU Ø26.5

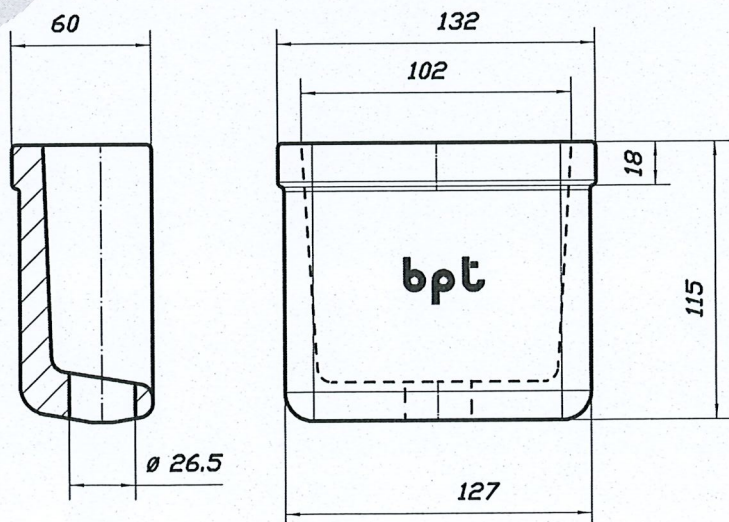

WIR FERTIGEN GESENKSCHMIEDETEILE
DROP FORGING OUR BUSINESS
NOUS ESTAMPONS TOUS LES ACIERS
NOI STAMPIAMO L'ACCIAIO

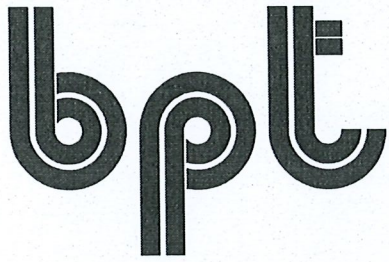

BATTISTA PORTERI S.R.L.

Via Statale 13

25060 Tavernole sul Mella (Brescia) ITALIA

Tel. 030/920131-920061-Fax 030/920783

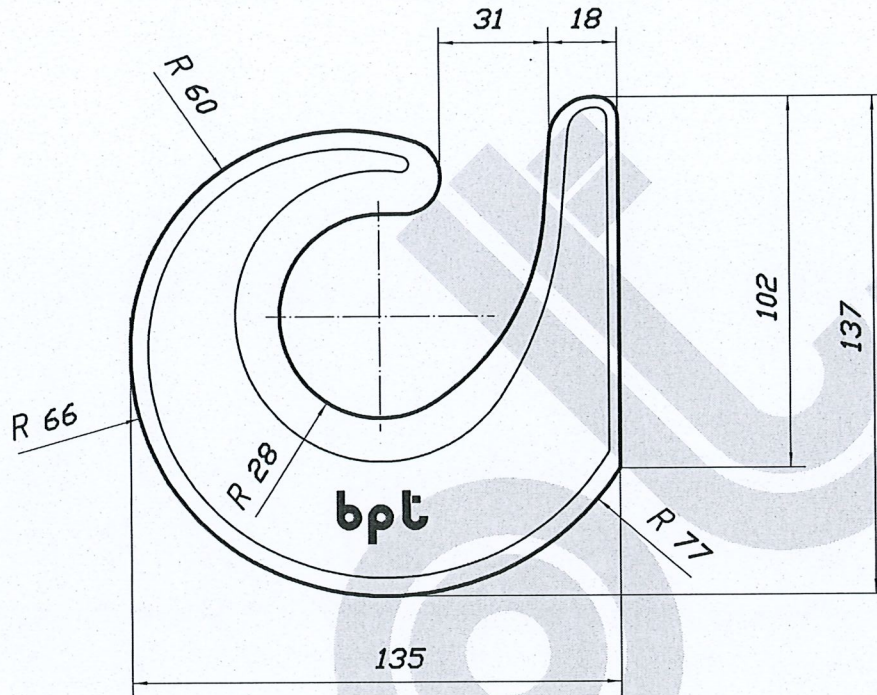

COD.

37063

GANCIO TRAINO N°5 Kg. 1.900

TOWING HOOK N°5 Kg. 1.900

SCHLEPPHAKEN N°5 Kg. 1.900

CROCHET DE REMORQUAGE N°5 Kg. 1.900

WIR FERTIGEN GESENKSCHMIEDETEILE
DROP FORGING OUR BUSINESS
NOUS ESTAMPONS TOUS LES ACIERS
NOI STAMPIAMO L'ACCIAIO